

# Blitz™

Code Milling Key Machine

**No. 1200CMB**

**Exploded View  
&  
Parts List Inside**

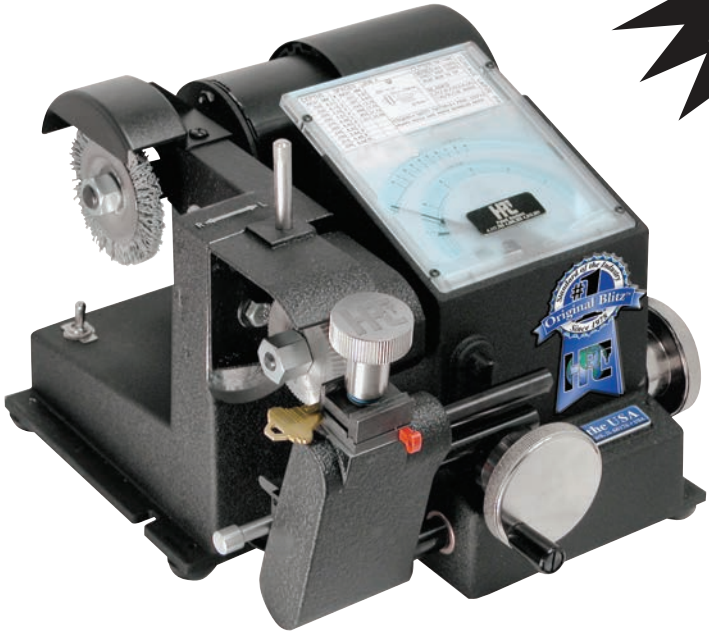

**Hudson Lock, LLC**  
81 Apsley Street  
Hudson, MA 01749



1-800-434-8960  
1-800-323-3295  
fax: 978.562.9859  
[sales@hudsonlock.com](mailto:sales@hudsonlock.com)



# INTRODUCTION

Congratulations on your purchase of the "Standard of the Industry" HPC Blitz™ Machine. From its introduction in the 1970's, it revolutionized the locksmith industry. The Blitz™ simplified the code cutting process, and its innovative design earned it 3 U.S. patents. It is the best selling code machine and has become an integral part of virtually every locksmith business.

The Blitz™ is very easy to use and extremely versatile. It cuts by actual manufacturer's depths and spaces. There is no need to convert to micrometer readings. With its rotating cutter head, the Blitz™ can cut high-security angle keys such as Medeco® (including Biaxial™)

This machine cuts accurate keys by code quickly and easily. The ease of changing from one manufacturer's specifications to another's is so simple, it is unparalleled. Even radically different changes can be set up in 10 to 30 seconds without wasting any key blanks.

This dramatic code cutting advancement is made possible through the use of code cards, which are inserted in the code machine. These cards have depth and space indicators, plus all the pertinent information such as cutter, jaw, code series, blanks and any special information you may need. Quite often, just replacing a code card is all that is required when making a change. Depth and space adjustments are never required in changing from one manufacturer to another. The Blitz™ Code Machine is a must for those who create master key systems or do code work.

A fully illustrated, step-by-step set of instructions is contained in the following pages. Please, be sure to spend some time reading and understanding all the steps thoroughly - so that NONE of the unique capabilities of this unusual machine is overlooked.

You will find, that cutting keys to dimensions more exact than the lock manufacturer's themselves produce is accomplished with extraordinary ease - on this machine!

## **PLEASE NOTE:**

- This manual is for all motorized 1200 series code machines. These include all models of the 1200CMB (ACDC, 240V etc.)
- All usage, adjustment and maintenance functions are the same on all models.
- **All pictures shown are of model 1200CMB.**

\*Medeco® is a registered trademark of Medeco Security Locks, Inc.



**Blitz™**  
No. 1200CMB



# PRODUCT PACKAGING CHECKLIST

## ACCESSORIES INCLUDED



Binder with Storage Panels\* (CARD-B\*)



Large Cylinders\* (installed on machine\*) (CW-14MC\*)



Automotive & Small Cylinders\* (CW-1011\*)



Red Tip Gauge (CM-1054MA)



Horseshoe Tip Gauge (CM-1054R)



Code Card Deck\* (DECK-150\*)



Key Gauging Shim (KBPS-1)



Cutter Shaft Wrench (WRENCH-1)



Allen Wrench 5/64" (WRENCH-2)



Cutter Nut Wrench (WRENCH-3)

Additional Accessories included with Extreme Blitz™

DECK-25 Code Cards  
CW-47MC Cutter  
TKA-CMB Tubular Adapter Kit  
CMB-CK Calibration Kit

\*NOT included with 1200B series machines

## OPTIONAL ACCESSORIES:



Carrying Case (1200 CASE)



Storage Panel (CARD-RP)



HPC Software



Tip Gauges (HT-125, HT-625, HT-SD, RT-SD)



Key Decoder (HKD-75)

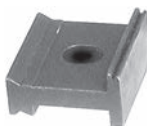

Medeco® Jaw (MJ-1)



Medeco KeyMark® Jaws (MJ-2)



Medeco® 3 Freedom Jaws (MJ-3)



Schlage PRIMUS® Jaw (SPJ-1)



Automotive Super Jaw (ASJ-1200)



GM 10-Cut/  
Ford 8-Cut Jaw (GMFJ-1)

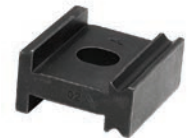

Kaba Peaks Jaw (KPJ-1)



Blitz™ Tibbe Key Adapter Kit (TIBBE-CMB)



Blitz™ Tubular Key Adapter Kit (TKA-CMB)



Calibration Kit (CMB-CK)



Quick Nut (QN-100B)



HPC Cutters

# INDEX

<b>SECTION</b>	<b>SECTION NUMBER</b>	<b>PAGE</b>
Code Cards.....	1.0.....	5
Cutters .....	2.0.....	9
Changing Cutters .....		14
Gauging and Holding Keys.....	3.0.....	17
Key Gauges .....		18
Standard Cylinder Key, Jaw A .....	3.1.....	20
Standard Cylinder Key, Jaw B.....	3.2.....	22
Red Full Short Tip Stop.....	3.3.....	24
Red Middle Short Tip Stop.....	3.4.....	26
Black Horseshoe Tip Stop .....	3.5.....	28
Medeco® Standard Commercial.....	3.6.....	30
Black Horseshoe, Full End Tip Stop.....	3.7.....	32
Depth and Space Crank Controls .....	4.0.....	35
Cutting the Key .....	5.0.....	39
Angle Cut Keys .....	6.0.....	55
Use of Swivel Cutter Head .....		66
Re-calibration of Depth.....	7.0.....	73
Cutting Too High or Low .....		76
Re-calibration of Space .....	8.0.....	77
Cutting Too Close or Too Far from the Tip.....		79
Cutting Too Far or Too Close to the Shoulder .....		90
Preventive Maintenance, Lubrication, Repairs and Guarantee.....	9.0.....	101
Exploded Views.....	10.0.....	105

# PARTS DESIGNATION CHART FOR THE 1200CMB CODE MACHINE

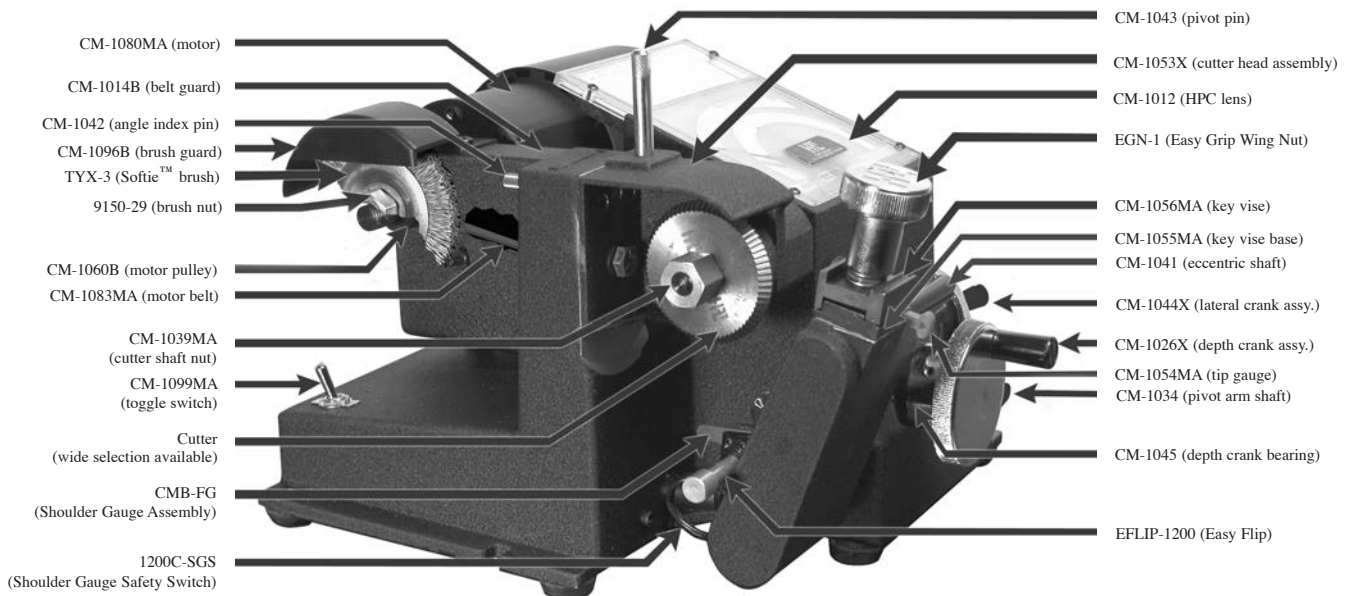

# 1.0

# CODE CARDS

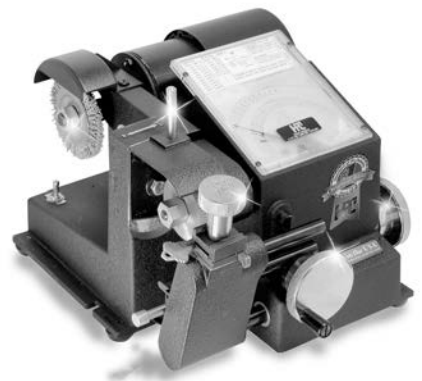

# 1.1 CODE CARDS

Jaw to use

Cutter to use

Applicable Code Series

Applicable Key Blanks

Important Notes

Key Placement

Space Increments

Depth and Space Dimensions in Inches and Millimeters

Depth Increments

Gauge Point

DEPTHS		SPACES		JAW: A		CUTTER: CW-1011	
#	INCH	MM	#	INCH	MM	SERIES:	ALL CODES FOR:
0			1	1.034	26.26	AA00-ZZ99/A000-Z999	MODULAR IGNITION PROGRAM (1010Y)
1	.315	8.00	2	.9415	23.91	0A00-6Z99/0000-6999	
2	.290	7.37	3	.8495	21.58		
3	.265	6.73	4	.7575	19.24		
4	.240	6.10	5	.6655	16.90		
5			6	.5730	14.55		
6			7	.4810	12.22		
7			8	.3890	9.88		
8			9	.2970	7.54		
9			10	.2045	5.19		
10			11				
11			12				

DEPTH INCREMENT: INCH .025, MM .635; SPACE INCREMENT: INCH .0925, MM 2.35

NOTE: GAUGE USING BLACK HORSESHOE TIP STOP

NOTE: CUTS ON BOTH SIDES OF KEY ARE SAME

NOTE: CUT ONE SIDE BY CODE, THEN DUPLICATE

COPYRIGHT © 1994 HPC, INC., SCHILLER PARK, IL USA  
DESIGNED AND MANUFACTURED BY HPC  
PRINTED IN USA

The Code Cards include all key cutting information.



**STORAGE** - When not in use, the Code Cards should always be returned to the slotted panels within the easel type “stand up” notebook and stored away from direct sunlight or extreme heat. The cards are inserted sideways with the notch to the right, so that the card number and manufacturer’s name shows. Additional storage panels may be ordered through your HPC Distributor.



**Hudson Lock, LLC**  
81 Apsley Street  
Hudson, MA 01749



1-800-434-8960  
1-800-323-3295  
fax: 978.562.9859  
[sales@hudsonlock.com](mailto:sales@hudsonlock.com)

# 2.0 CUTTERS

# STANDARD CUTTERS FOR THE BLITZ™ MACHINE

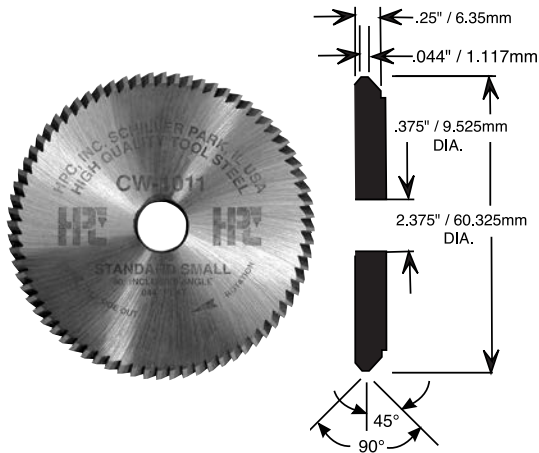

No. CW-1011 (Tool Steel)  
 No. CW-1011CC (Carbide)-Optional  
 90° angle, small cylinder cutter for automotive, furniture and padlock keys.

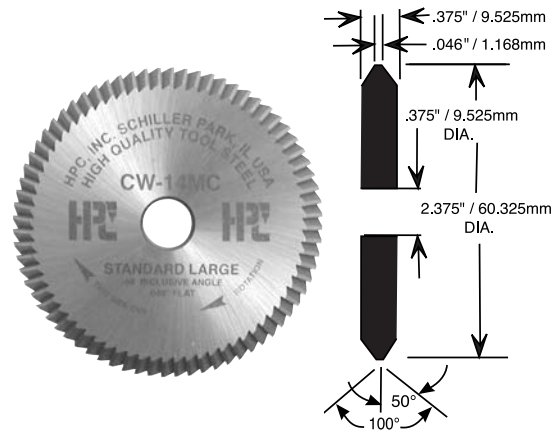

No. CW-14MC (Tool Steel)  
 No. CW-14MCC (Carbide)-Optional  
 100° angle, standard large cylinder cutter for Schlage, KwikSet, Yale, etc.)

The CW-14MC and CW-1011 are included with the Original Blitz™ machine (No. 1200CMB) and the Extreme Blitz™ (No. 1200CMBX). Optional carbide versions are also available for longer cutter life.

# ADDITIONAL CUTTERS FOR THE BLITZ™ MACHINE

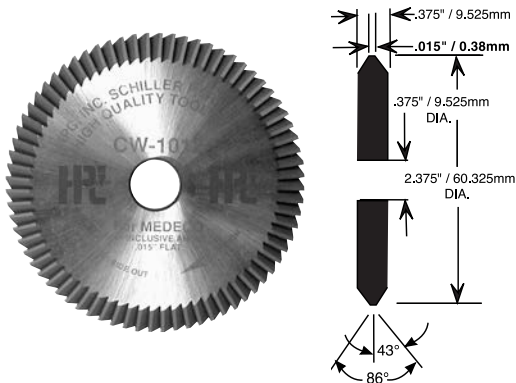

No. CW-1012 (Tool Steel)  
 Specialty cutter has proper angle and pin seat for cutting Medeco® High Security keys.

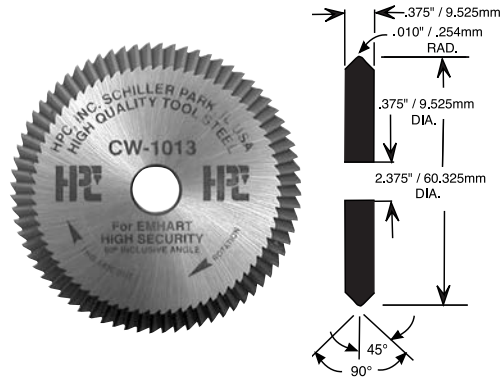

No. CW-1013 (Tool Steel)  
 Only available cutter with exact angle of cut and full “V” pin seat for Emhart High Security keys.

\*Medeco® is a registered trademark of Medeco Security Locks, Inc.

# ADDITIONAL CUTTERS FOR THE BLITZ™ MACHINE

## (CONTINUED)

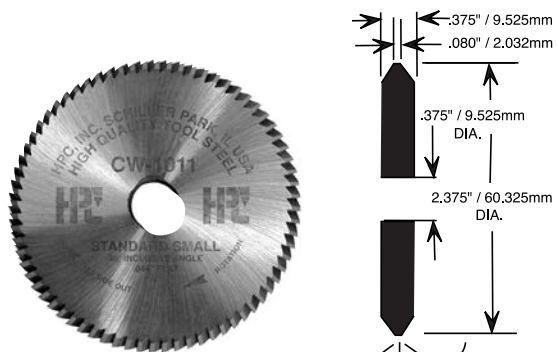

*No. CW-1014 (Tool Steel)*  
 This specially designed cutter has .080 flat for one step cutting of keys for Kwikset, Weslock, and Weiser locks using original pins.

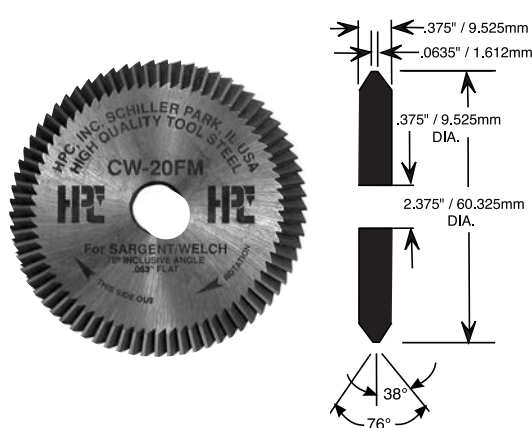

*No. CW-20FM (Tool Steel)*  
 76°, double angle, flat mill tooth for Sargent and Welch keys.

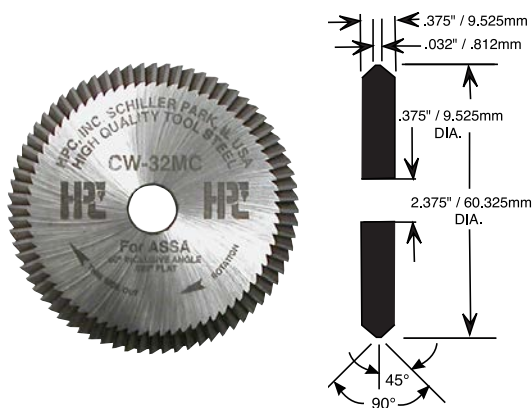

*No. CW-32MC (Tool Steel)*  
 Specially designed 90° angle, tool steel cutter for ASSA keys with .032 flat.

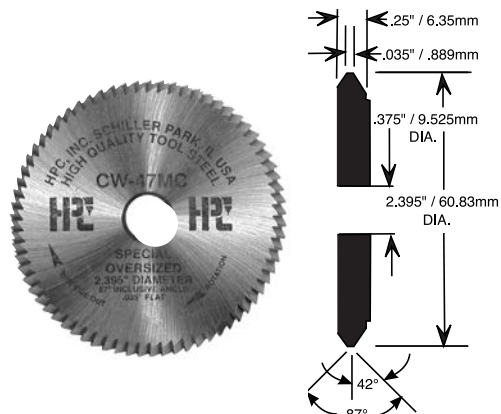

*No. CW-47MC (Tool Steel)*  
*No. CW-47MCC (Carbide)-Optional*  
 87° angle, tool steel cutter for some automotive keys. Included with the Extreme Blitz™ (No. 1200CMBX)

The correct cutter to be used is printed on each card. One of the important features of this machine is its ability to maintain correct depths and spaces with virtually no set-up time involved, even when changing cutters. This feature is reliant upon using cutters whose outside diameters are matched and equal.

# ADDITIONAL CUTTERS FOR THE BLITZ™ MACHINE (CONTINUED)

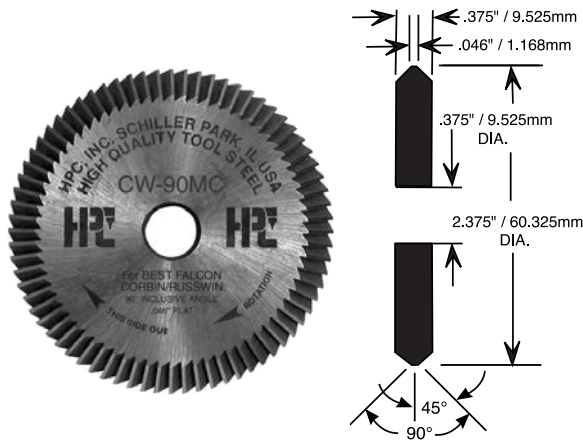

No. CW-90MC (Tool Steel)  
90° angle, large cylinder cutter for shallow & deep cuts in adjacent positions. For Best, Falcon, Eagle, Arrow, Kaba, and IC core.

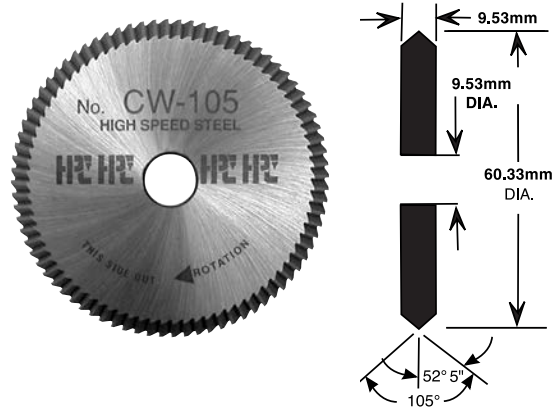

No. CW-105 (Tool Steel)  
105°, double angle cutter for ASSA.

# SLOTTER CUTTERS FOR THE BLITZ™ MACHINE

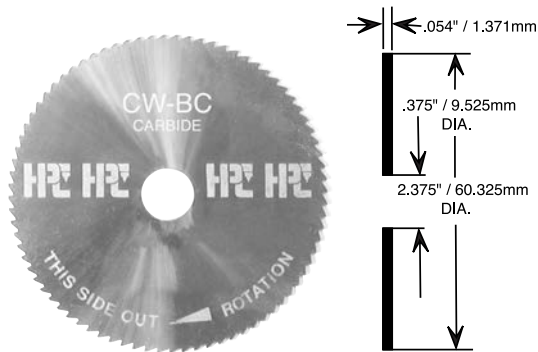

No. CW-BC\*-(Carbide)  
.054 carbide slotter cutter for Yale.  
\*(requires spacer SPR-5)

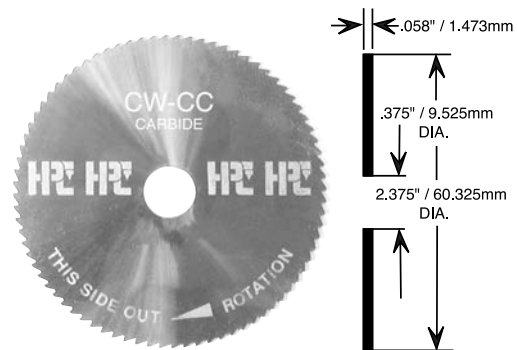

No. CW-CC\*-(Carbide)  
.058 carbide slotter cutter for S&G, Yale, Lloyd Matheson.  
\*(requires spacer SPR-5)

# MORE SLOTTER CUTTERS FOR THE BLITZ™ MACHINE

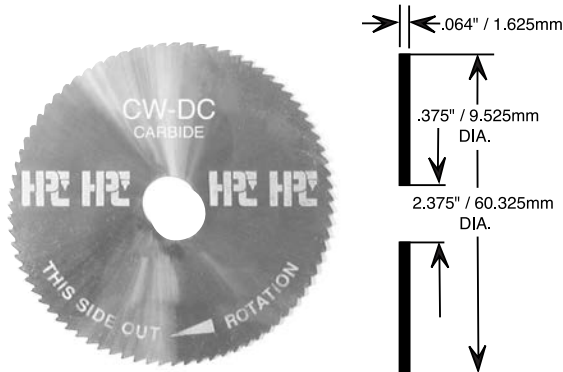

No. CW-DC\*-(Carbide)  
 .064 carbide slotter cutter for S&G.  
 \*(requires spacer SPR-5)

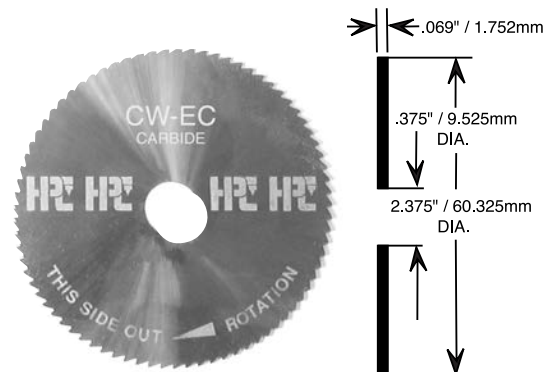

No. CW-EC\* -(Carbide)  
 .069 carbide slotter cutter for Diebold.  
 \*(requires spacer SPR-5)

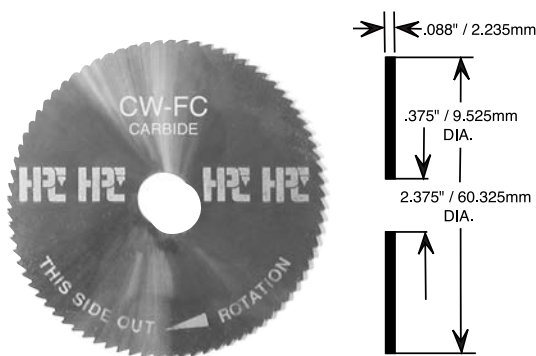

No. CW-FC\* -(Carbide)  
 .088 carbide slotter cutter for Mosler.  
 \*(requires spacer SPR-5)

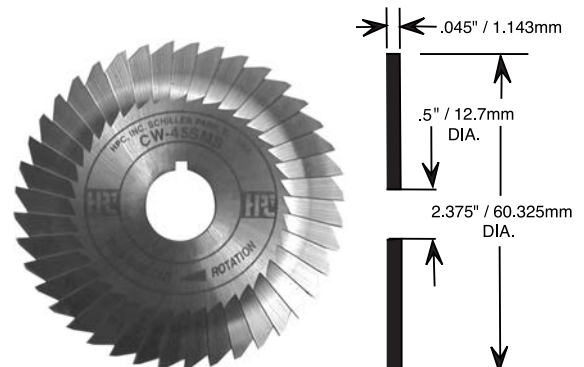

No. CW-45SMS\* -(Tool Steel)  
 .045 M2 tool steel combination standard/flat  
 steel cutter for safety deposit boxes.  
 \*(requires spacer SPR-5)

# CHANGING CUTTERS

The following procedure is recommended when changing from one cutter to another.

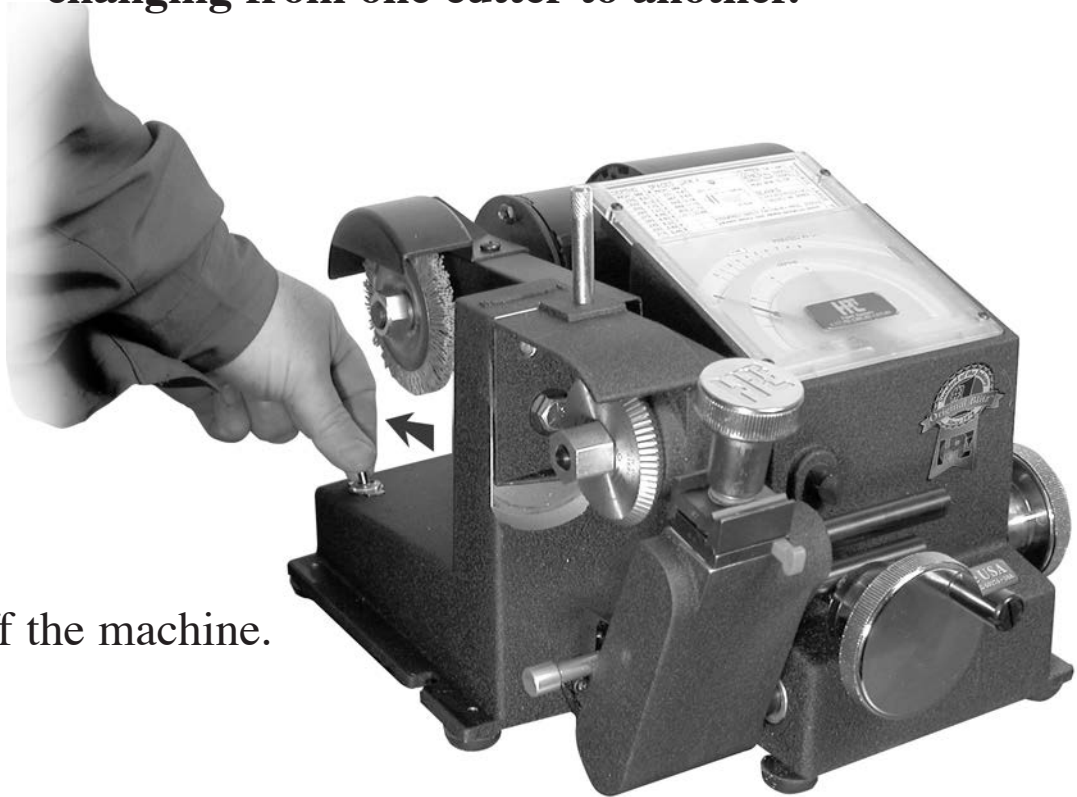

Turn off the machine.

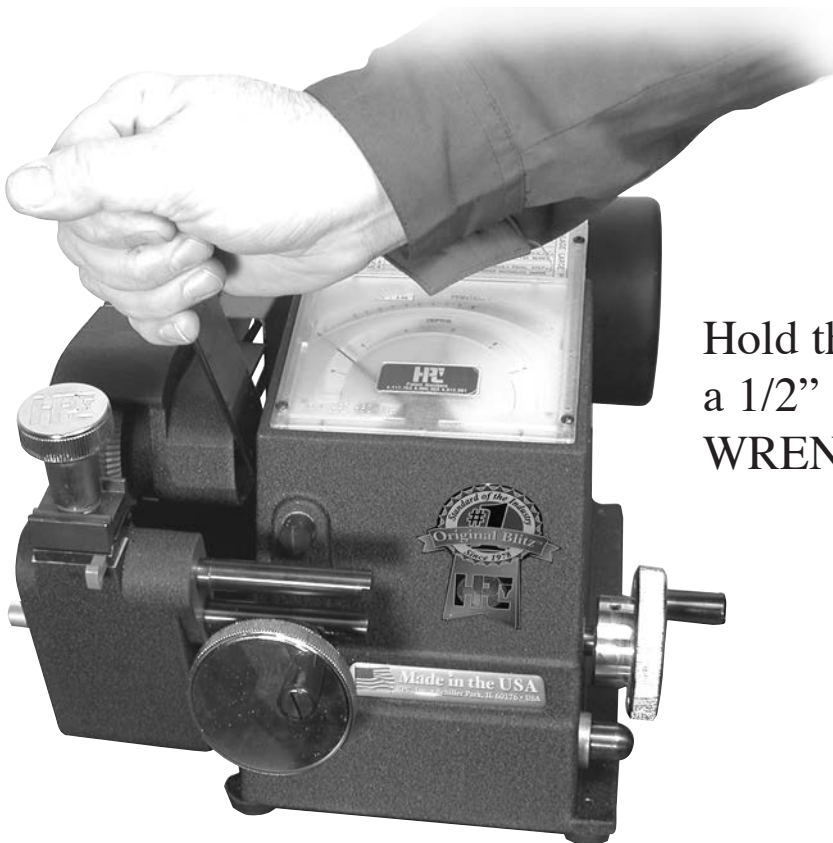

Hold the cutter shaft fast with a 1/2" open end wrench. (No. WRENCH-1 supplied)



**HOLD**

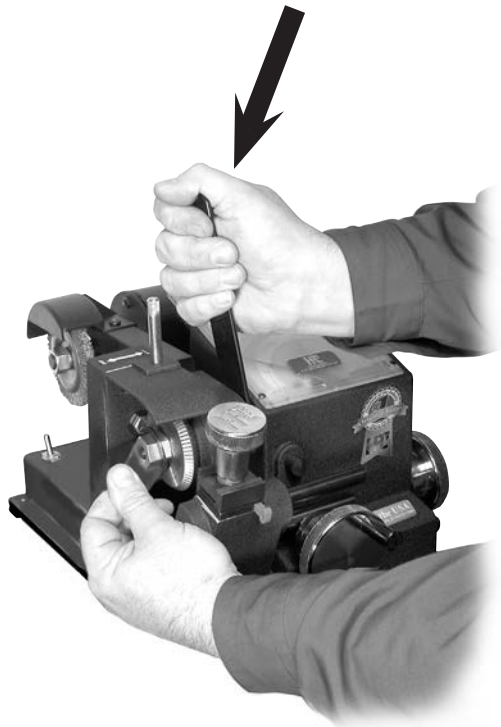

**HOLD**

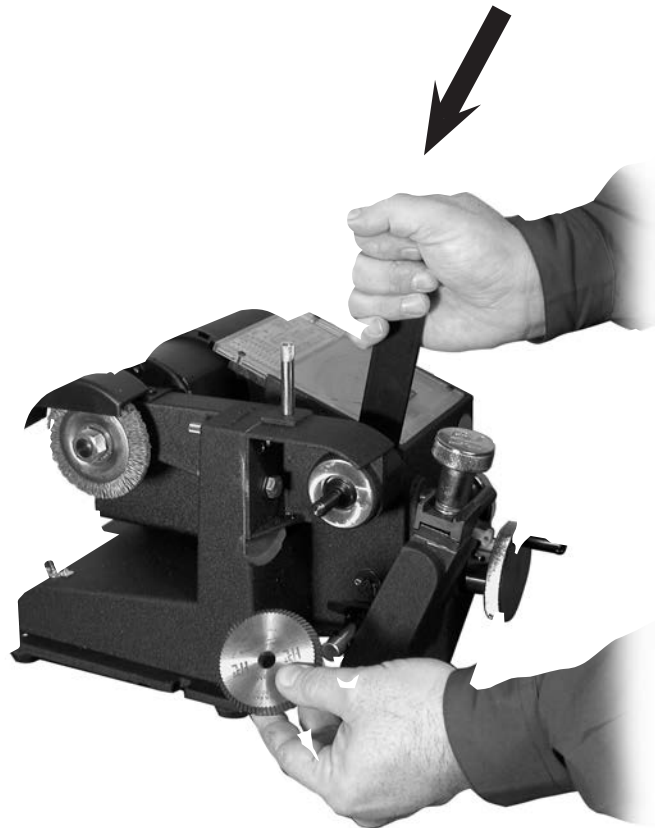

Loosen the cutter shaft nut, with a 3/4" open end wrench (No. WRENCH-3 supplied) by turning it clockwise (left hand thread). Remove the cutter.

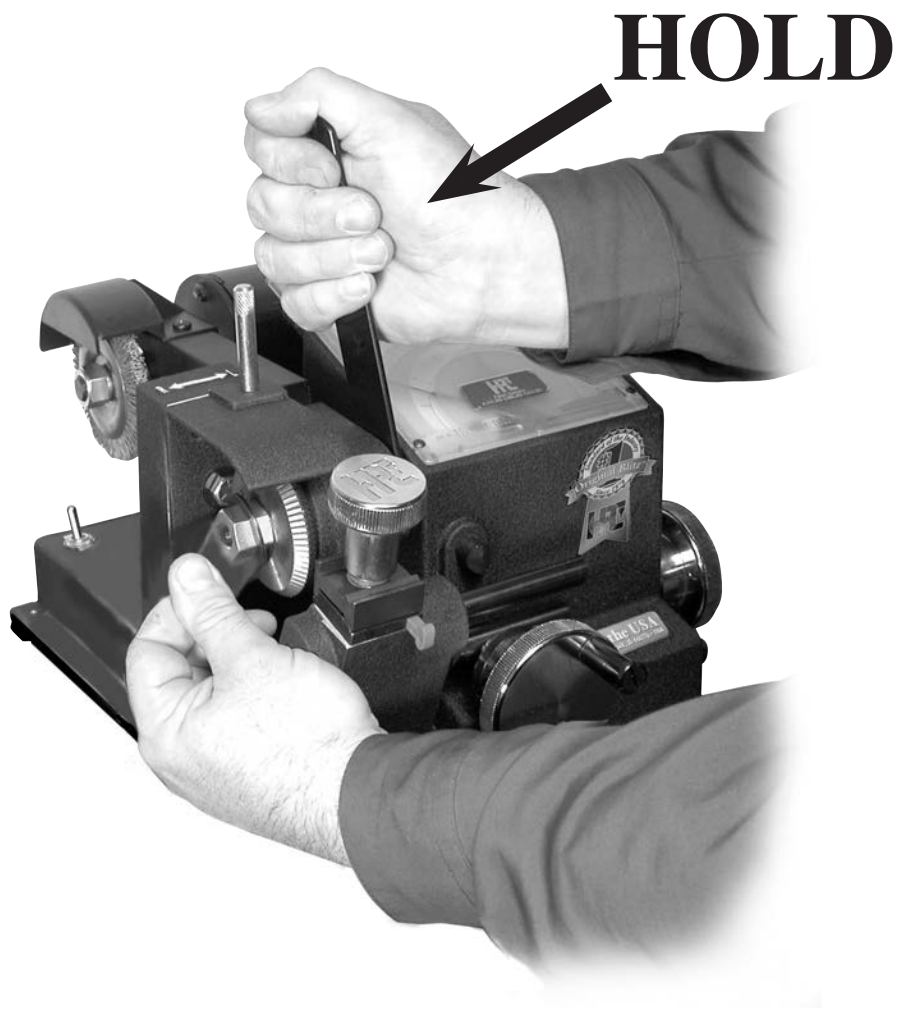

- Slide the replacement cutter wheel onto the shaft.  
**IMPORTANT:** Be sure cutter is installed for a clockwise rotation!
- Hold the shaft with the 1/2" wrench.
- Install the nut, turning it counter-clockwise onto the shaft with the 3/4" wrench. **Do not overtighten the nut.**

# 3.0

## GAUGING AND HOLDING KEYS

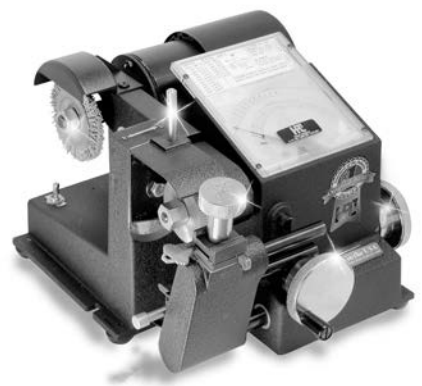

## KEY GAUGES



Red (Plastic) Tip Gauge  
No. CM-1054MA

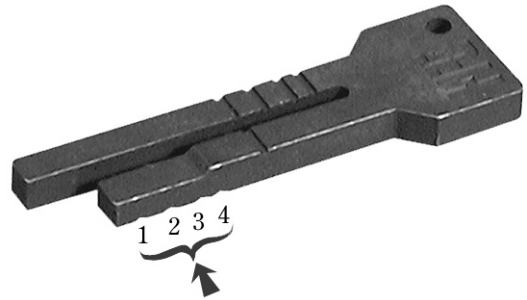

Black (Horseshoe) Tip Gauge  
No. CM-1054R

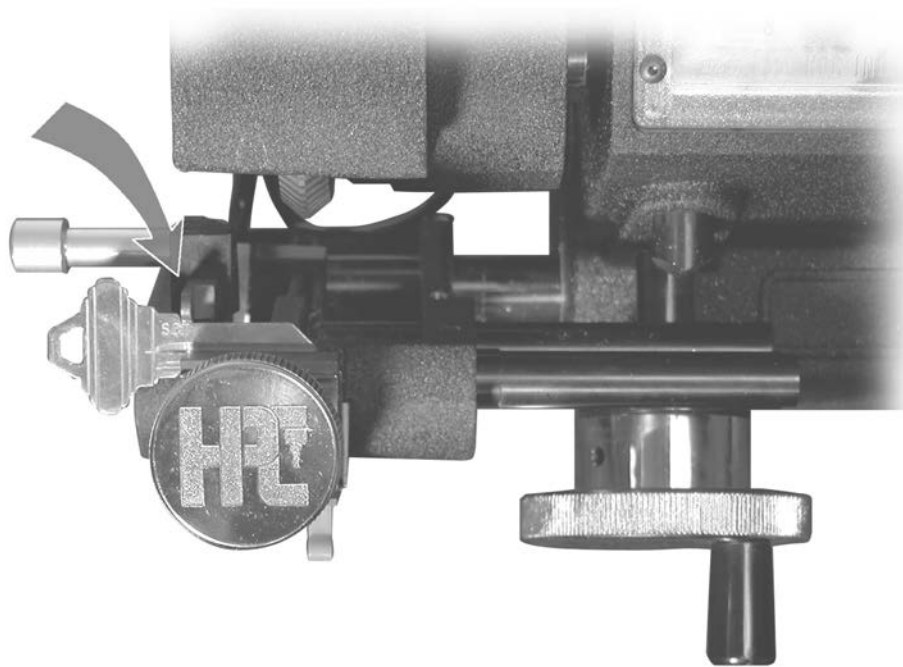

Shoulder Gauge  
No. CMB-FG

# SHOULDER GAUGE SAFETY SWITCH

This machine is equipped with a Shoulder Gauge Safety Switch to protect the shoulder gauge from being accidentally damaged by the cutter. This type of accident occurs if the shoulder gauge is left up at the key after gauging rather than being lowered to its rest position before cutting the key.

## Cutting A Key

To cut a key you must lower the gauge to its rest position before turning on the cutter motor. Turning on the cutter motor is accomplished with the switch at the rear of the machine. Turning on the machine's cutter motor with the shoulder gauge not in the rest position will result in the safety switch relay disengaging the cutter motor's power. This will also happen if the gauge is moved from its rest position while the cutter motor is already on.

## Resetting the Machine

To reset the machine, lower the shoulder gauge to its rest position, then turn off the machine with the regular switch located at the rear of the machine. The machine should now be turned back on to cut the key. Resetting the machine prevents the Shoulder Gauge Safety Switch from being used as a power switch to turn the machine on and off.

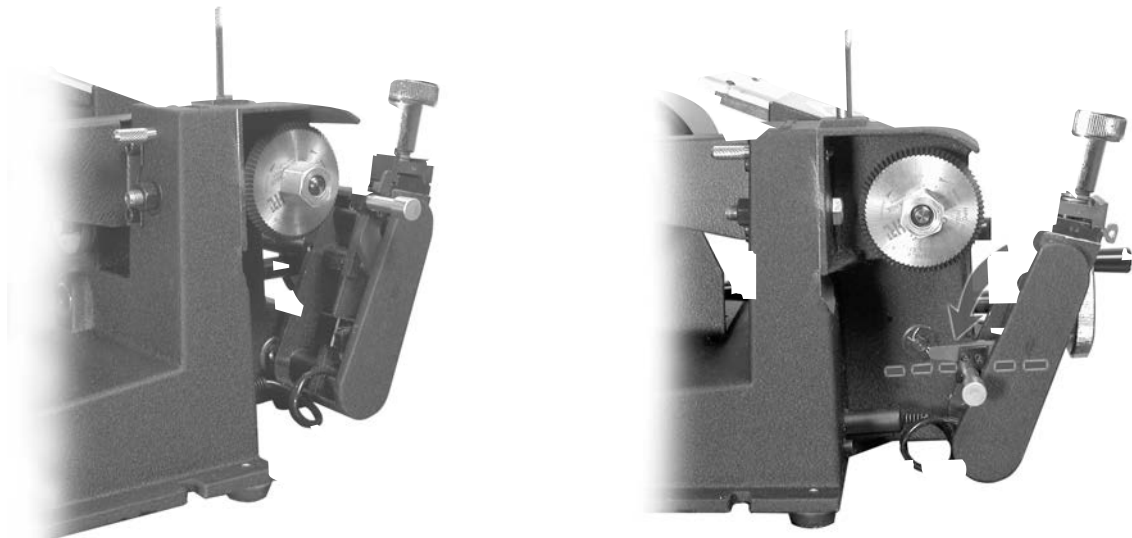

# SECTION 3.1

No. CMB-FG  
Shoulder Gauge

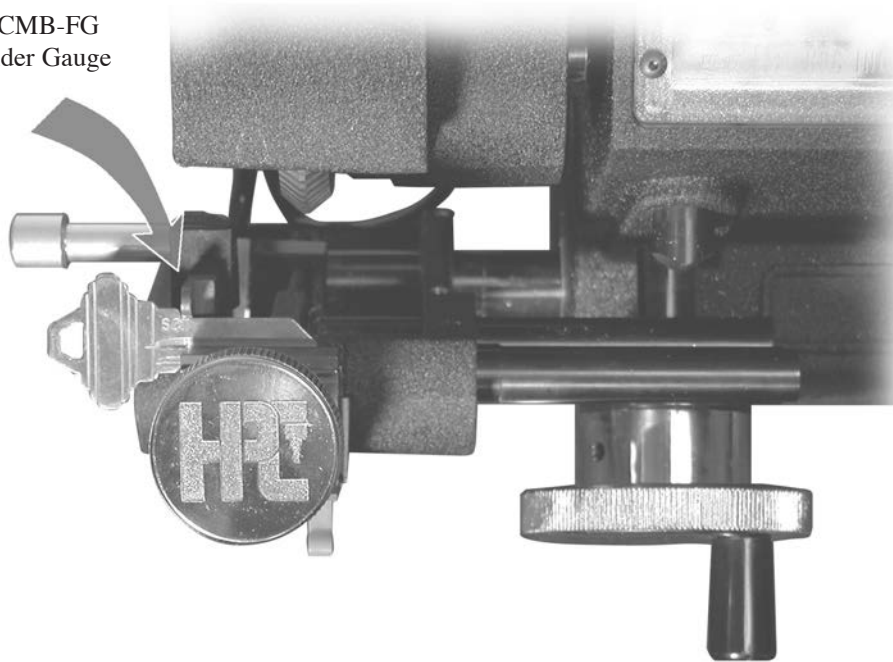

## STANDARD CYLINDER KEY WITH SHOULDER GAUGING USING JAW A.

(Example: Schlage, Card No. C45)

Place key blank in the jaw with the shoulder touching the left hand edge of shoulder gauge. Flip the shoulder gauge down before turning on the motor. The space dimension can be significantly affected by any damage incurred to the shoulder gauge.

Damage to the shoulder gauge can occur when it comes in contact with the cutter, or when undue pressure is used when gauging against the key's shoulder.

No. CM-1054MA  
Key Vise Tip Gauge

Key vise tip gauge pulled  
to rear and into Position  
No. 1.

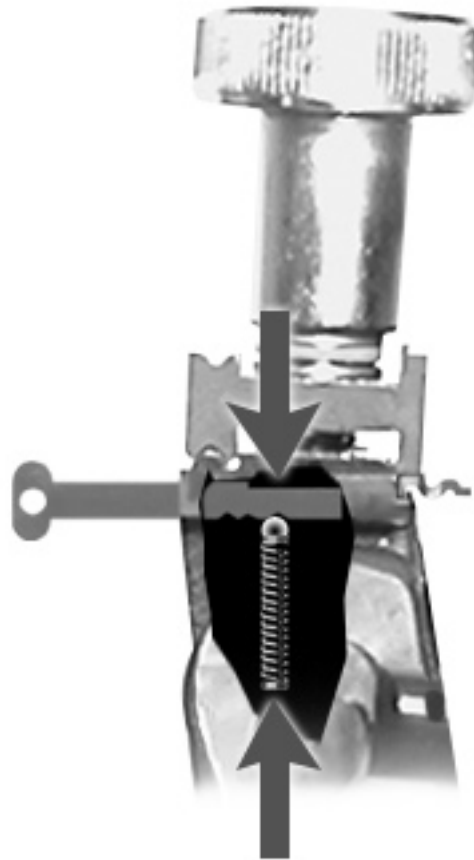

**Wing nut and top jaw of  
vise removed to show  
a top view of the bottom  
jaw only, for key  
positioning.**

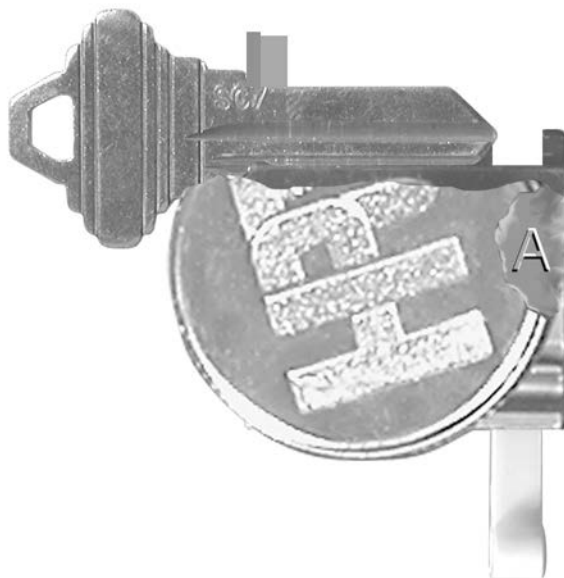

Make sure the key is  
laying flat against ledge  
before tightening wing nut.

# SECTION 3.2

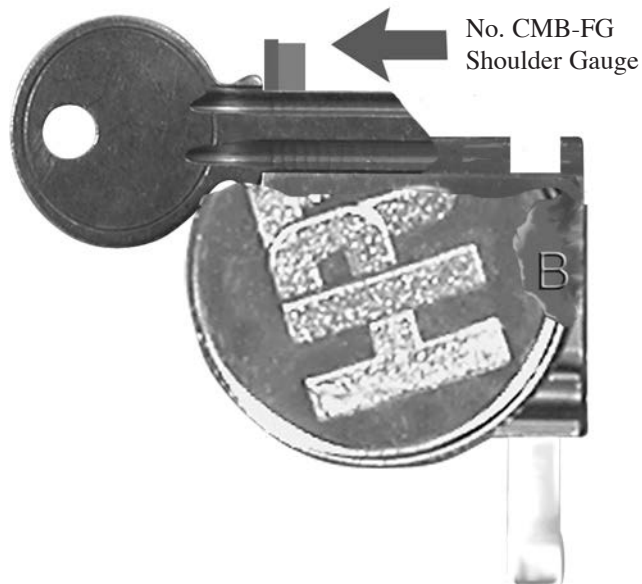

## STANDARD CYLINDER KEY WITH SHOULDER GAUGING USING JAW B.

(Example: Master, Card No. C34)

Key shoulder touches left hand edge of shoulder gauge.  
Flip gauge down before turning on motor.



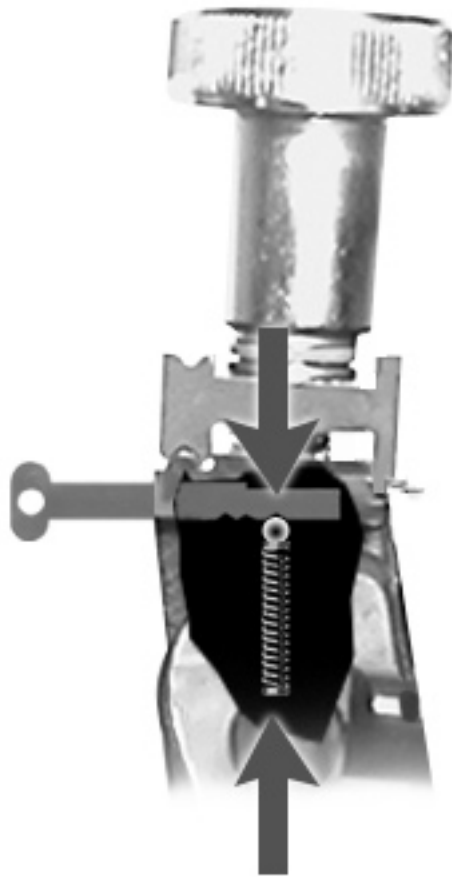

No. CM-1054MA  
Tip Stop

Key lays in front of lip.  
Key vise tip gauge pulled to rear. (Position No. 1)

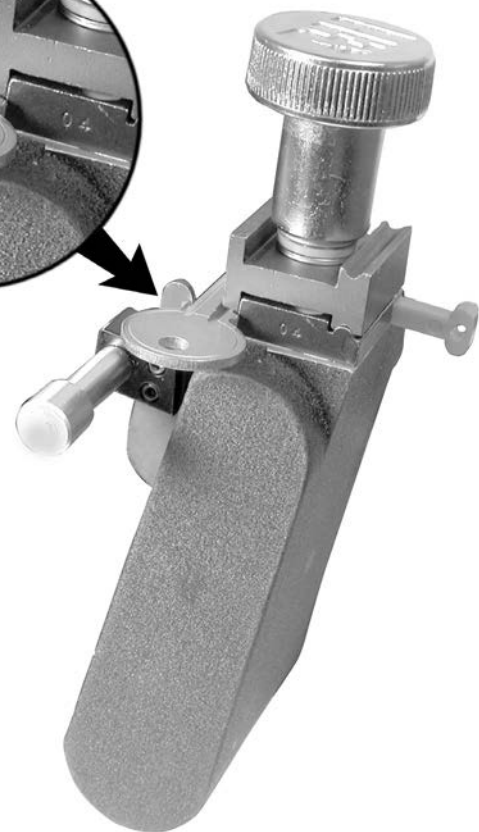
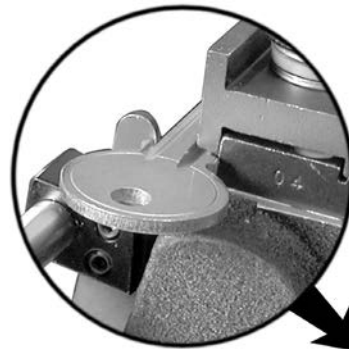

Make sure the key is laying flat against ledge, before tightening the wing nut.

# SECTION 3.3

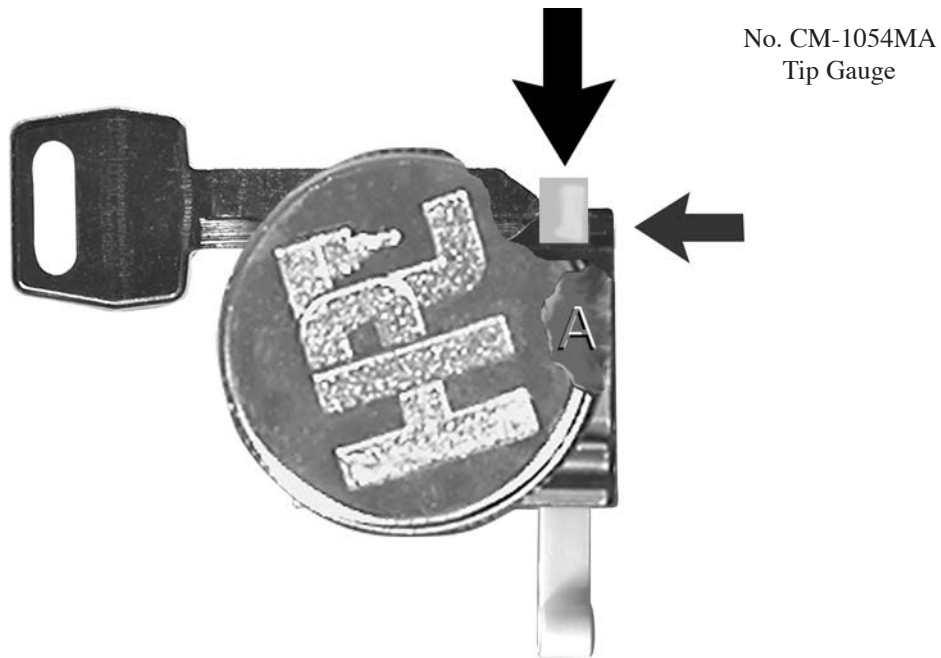

## RED FULL SHORT TIP STOP GAUGING USING JAW A.

(Example: Ford, Card No. C24)

Key is gauged from tip.

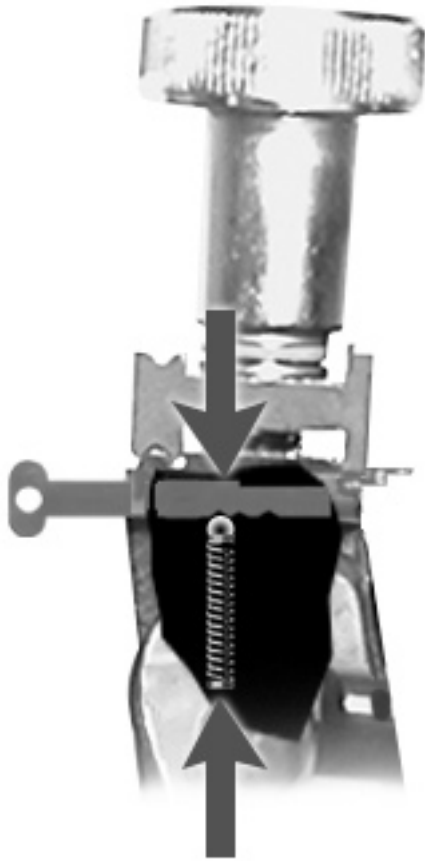

No. CM-1054MA  
Gauge in 3rd groove.

Key vise tip gauge, pushed inward to the third groove position. Tip gauge is pulled to rear while cutting.

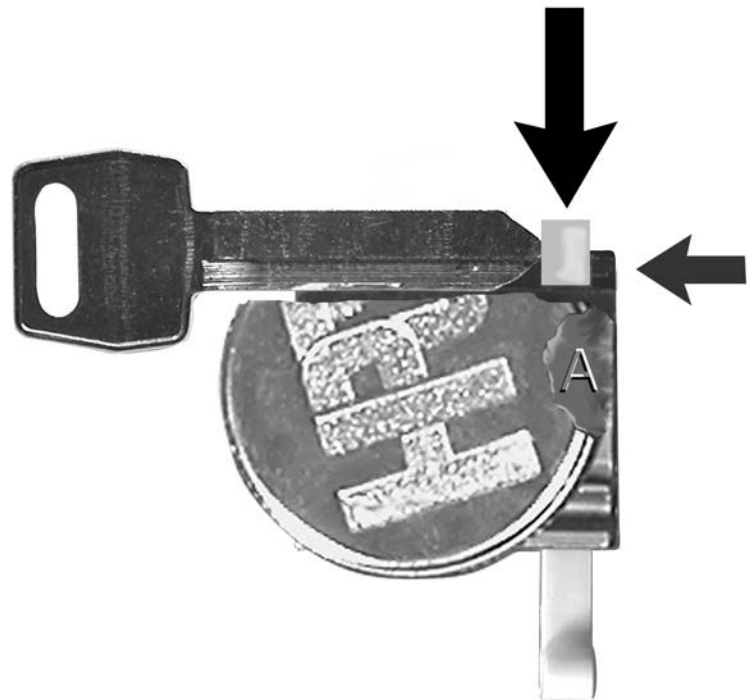

**Wing nut and top jaw of vise removed to show a top view of the bottom jaw only, for key positioning and stop bar settings.**

Key blank grooving edge lays directly on face of key vise or key vise base, for ignition and trunk keyway. No riser blocks used.

# SECTION 3.4

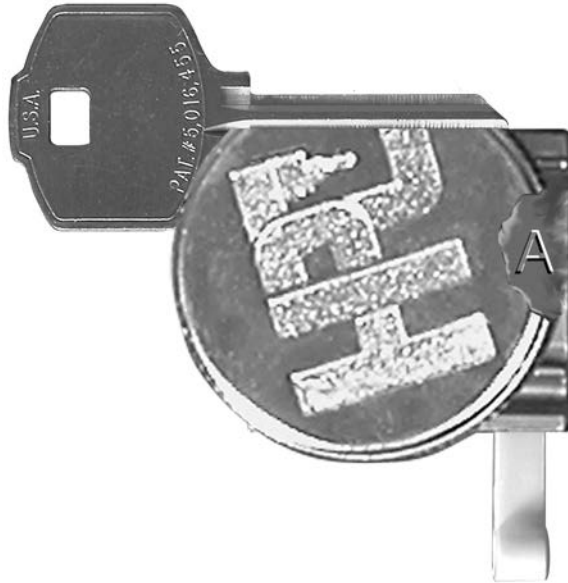

No. CM-1054MA  
Tip Gauge

## RED MIDDLE SHORT TIP STOP GAUGING USING JAW A.

(Example: KABA-PEAKS 6-Pin, Card No. CPKS1)

Key is gauged from bottom stop, not tip.

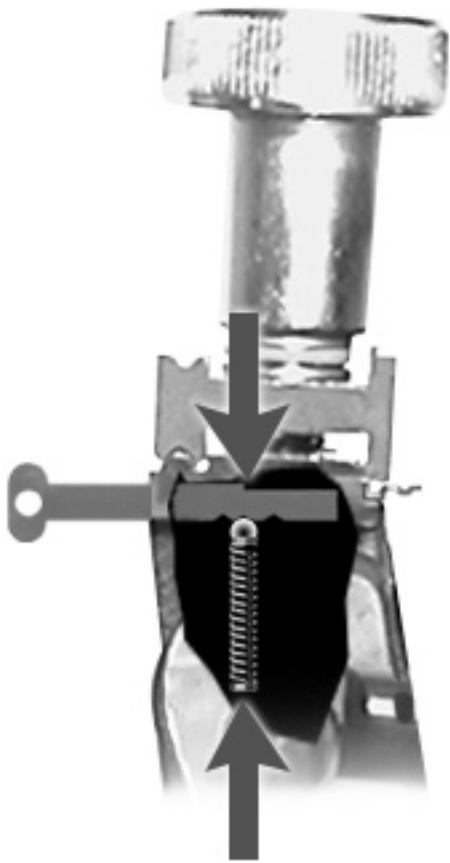

Key vise tip gauge, pushed inward to the second groove position. Tip gauge is pulled to rear while cutting.

No. CM-1054MA  
Key Vise in 2nd Position.

Top jaw of vise removed to show a top view of the lower jaw only, for key positioning and stop bar settings.

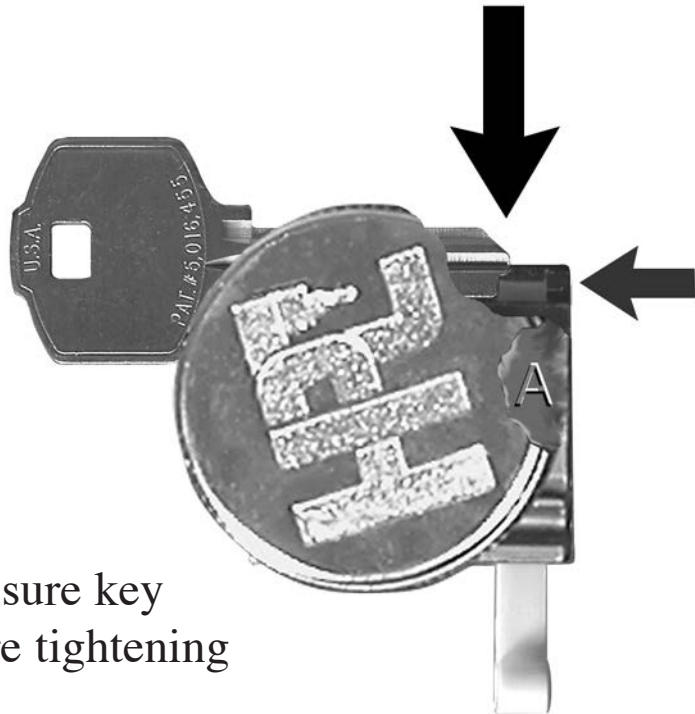

Gauge against tip stop. Be sure key lays flat against ledge before tightening wing nut.

\*For BEST type blanks see section 3.5

# SECTION 3.5



## BLACK HORSESHOE SHORT TIP STOP GAUGING USING JAW B.

(Example: Best Card No. C3)

Key is gauged from bottom stop, not tip.  
(Note: Use black tip gauge, NOT red.)

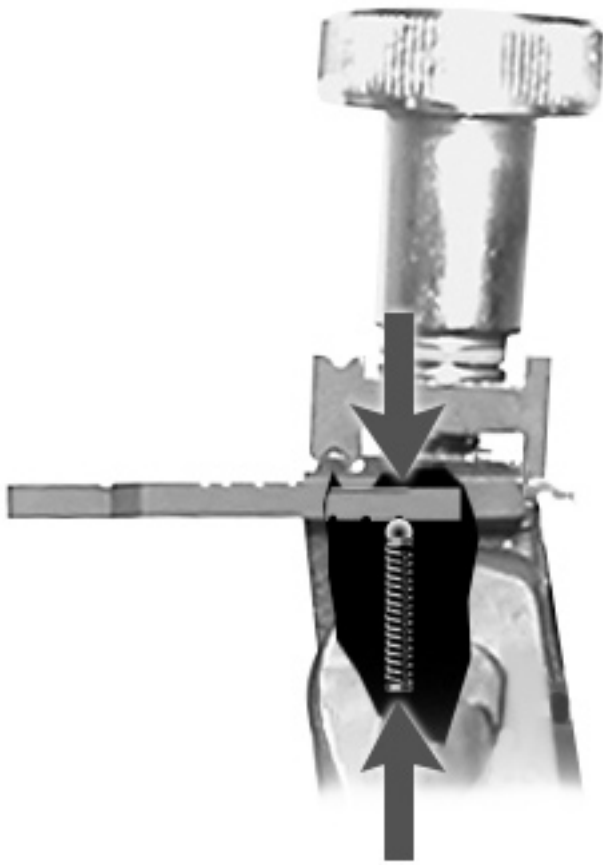

Gauge pushed inward to first groove position.

Note special holding on key milling using jaw "B" side. (Key must lay flat against back ledge of bottom jaw as shown.)

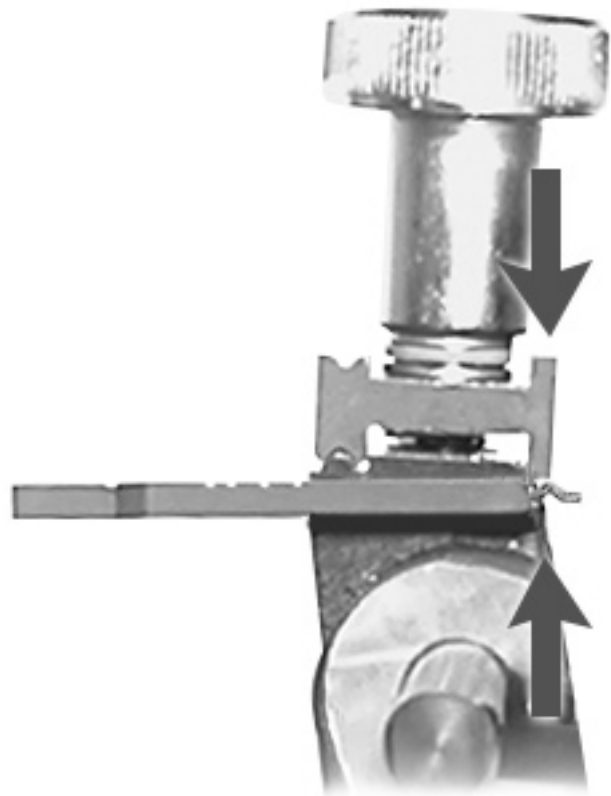

# SECTION 3.6

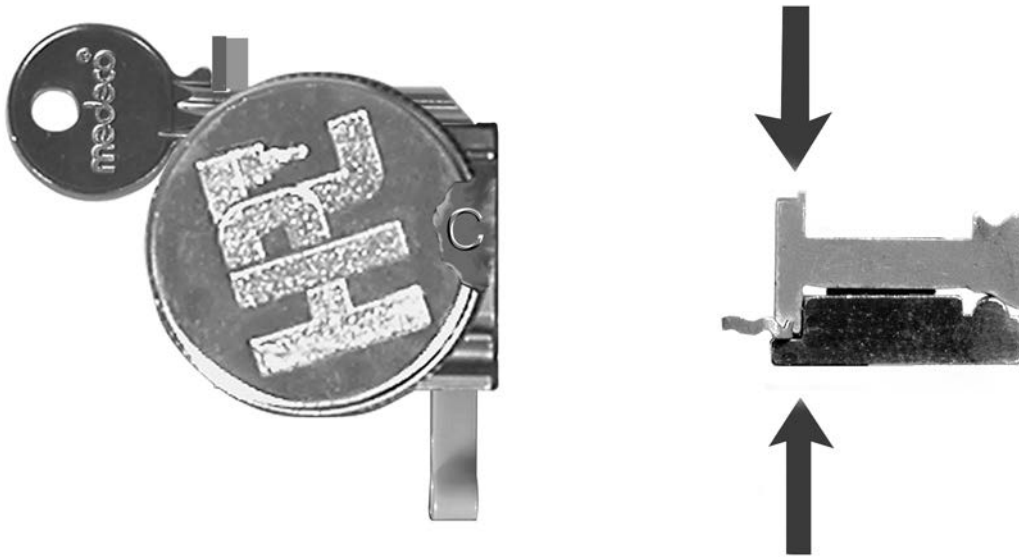

## MEDECO® - STANDARD COMMERCIAL USING JAW C. (OPTIONAL EQUIPMENT)

(Example: Medeco® Card No. C36)

\*Medeco® is a registered trademark of Medeco Security Locks, Inc.

Key shoulder touches left hand edge of shoulder gauge. Flip gauge down before turning on motor.



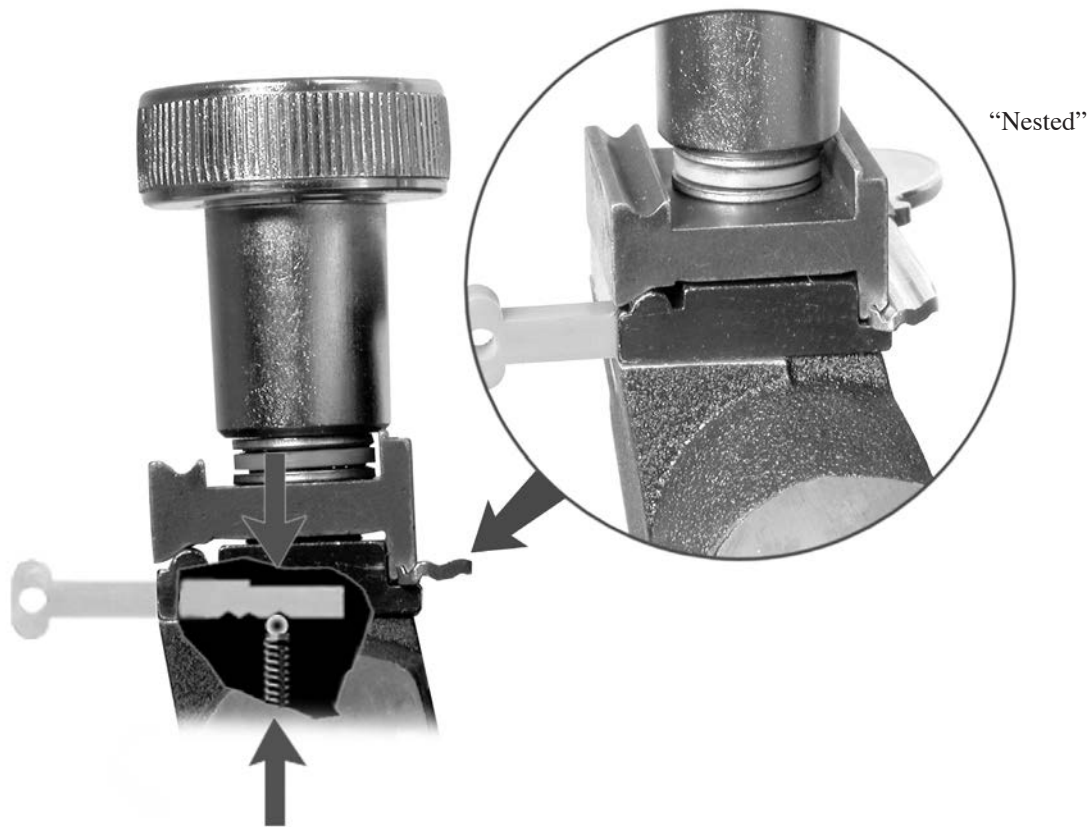

Jaw and grooves “nest” into each other. Key vise tip gauge is pulled back to rear. Open jaw “C” only enough to slide key into position. Be sure key groove and jaw milling mate before tightening wing nut.

# SECTION 3.7

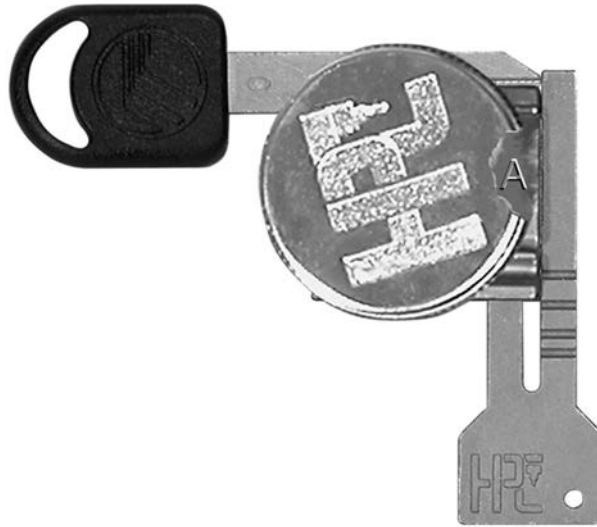

## BLACK HORSESHOE FULL END TIP STOP GAUGING USING JAW A OR B.

(Example: GM Modular 94+, Card No. CF215)

Key is gauged from tip as shown.  
(Note: Black tip gauge NOT Red.)

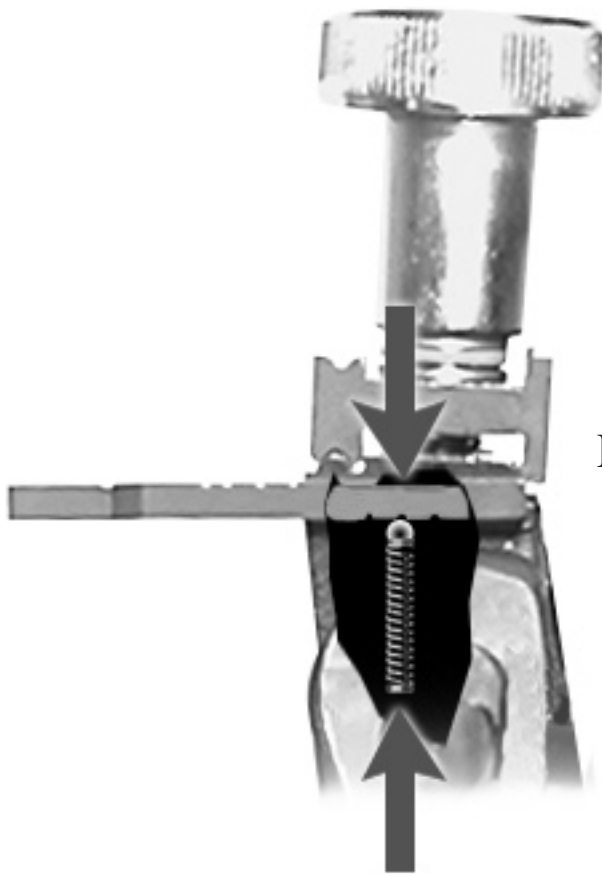

Detent in second groove position.

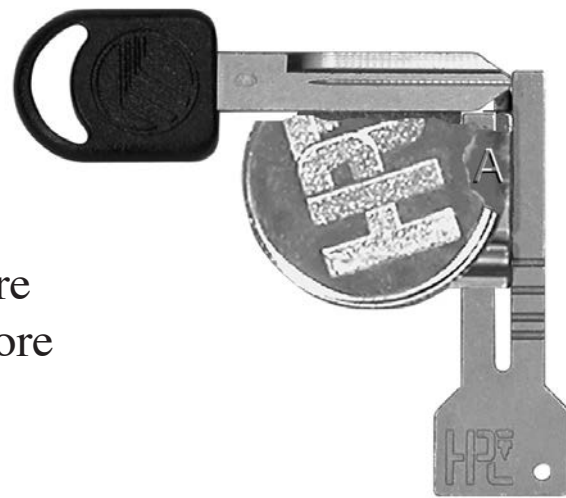

Gauge against tip stop. Be sure key lays flat against ledge before tightening wing nut.

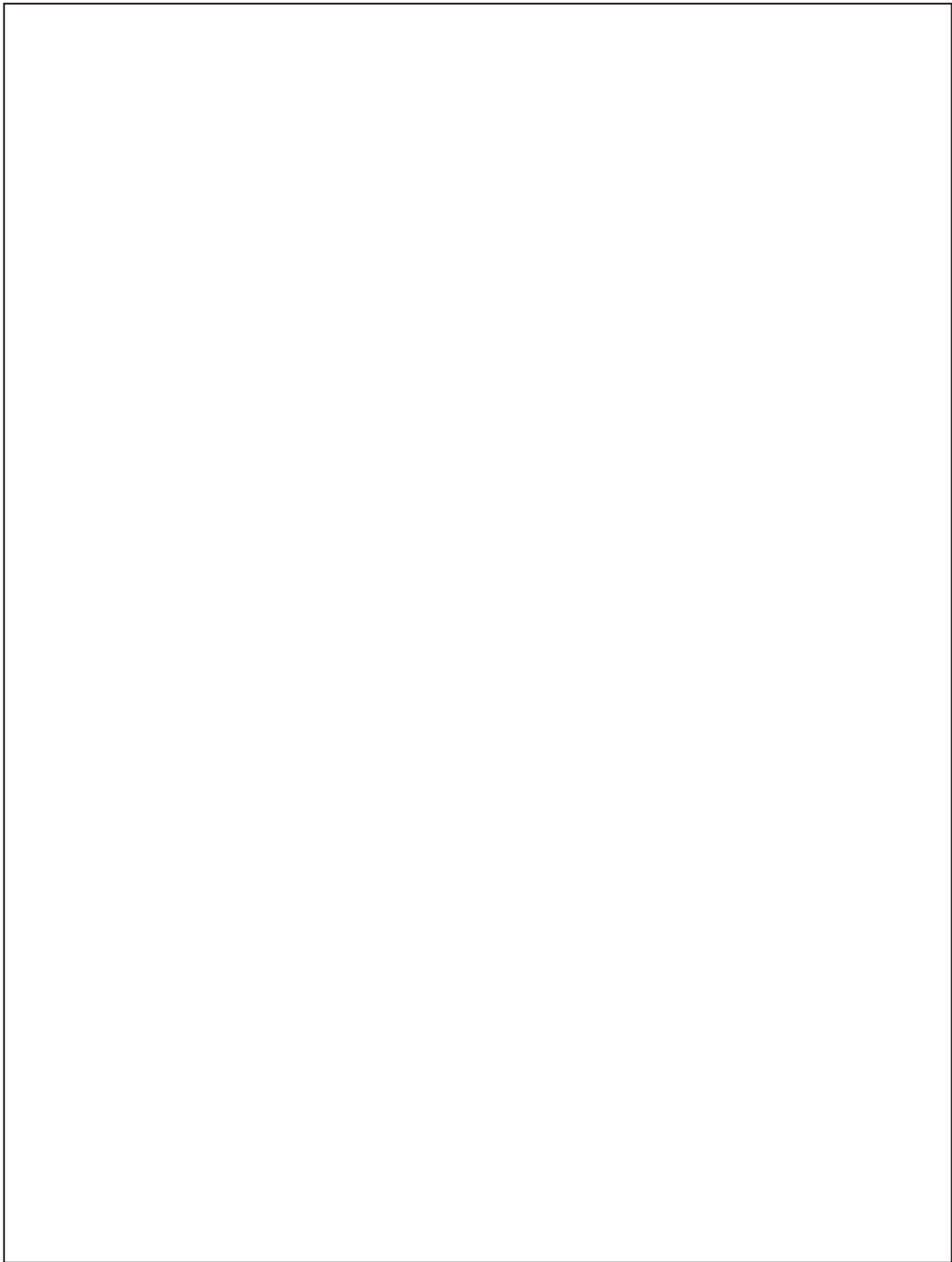

# 4.0

## DEPTH AND SPACE CRANK CONTROLS

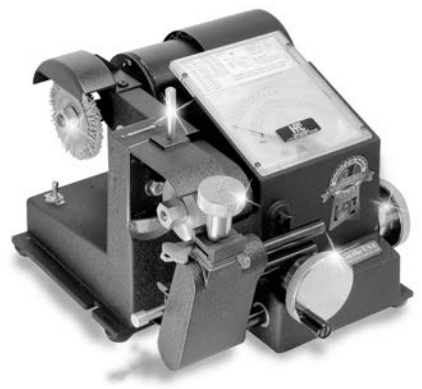

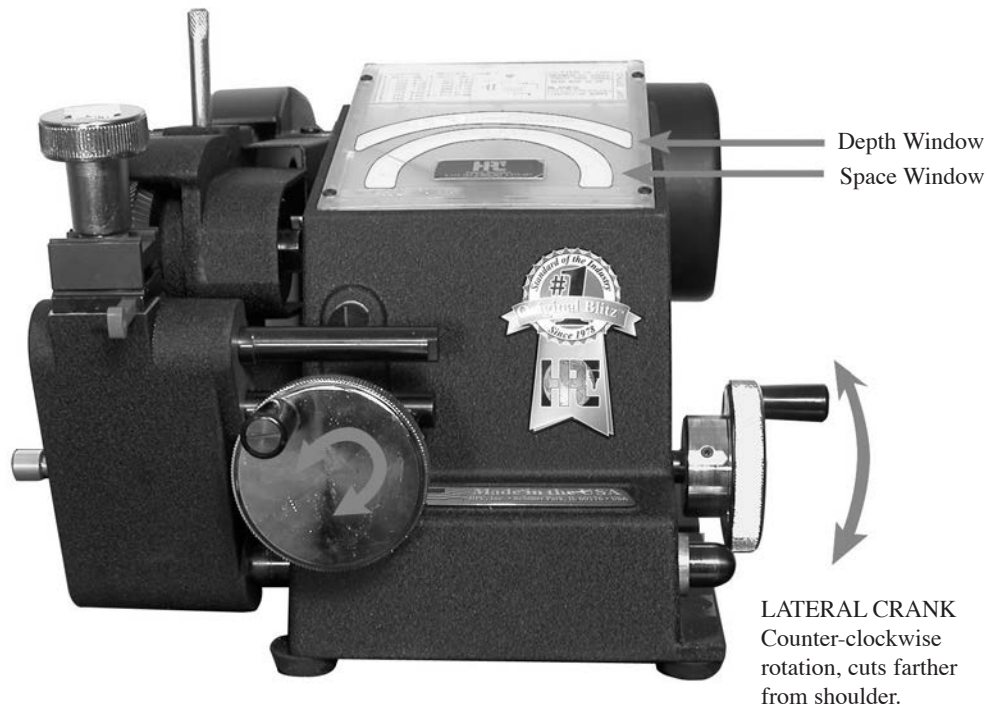

**DEPTH CRANK**  
 Clockwise rotation,  
 cuts deeper.

**LATERAL CRANK**  
 Counter-clockwise  
 rotation, cuts farther  
 from shoulder.

### **DEPTH CRANK**

THE DEPTH OF A CUT is controlled by rotating the No. CM-1026X Depth Crank, located at the front of the machine. Clockwise rotation, as indicated above, moves the key inward towards the cutter. Counter-clockwise rotation moves the key outward and away from the cutter.

### **LATERAL CRANK**

THE LATERAL MOVEMENT of the key is controlled by rotating the No. CM-1044X lateral crank located on the right hand side of the machine. Counter-clockwise rotation moves the key to the left and causes the cutter to cut farther from the shoulder.

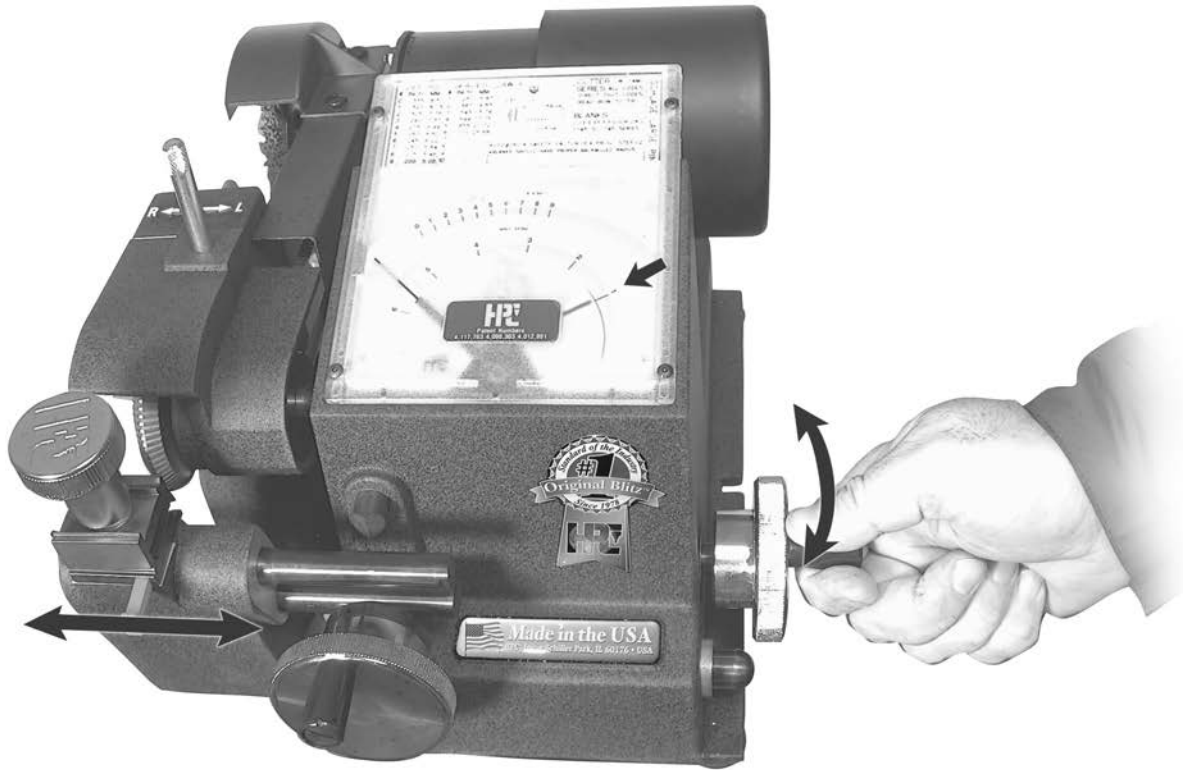

Rotating the lateral crank clockwise moves the pivot arm to the right, and rotating counter-clockwise moves it to the left.

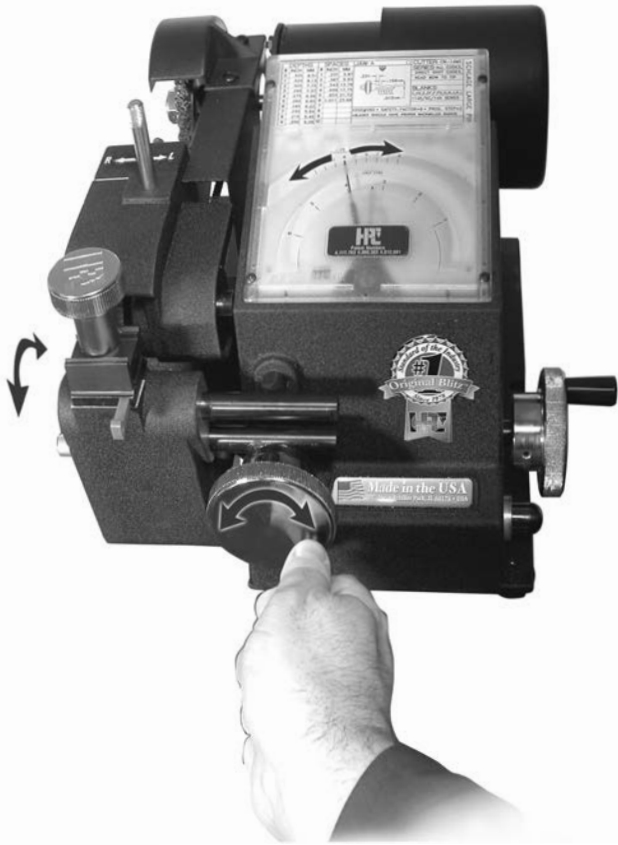

Rotating the depth crank clockwise, the pivot arm will move inward towards the cutter, rotating counter-clockwise will move it outward away from the cutter.

The depth indicator needle sweeps across the face of the arc, from left to right as the knob is advanced. With this indicator needle centered over the mark on the card, the key is cut to the corresponding depth.

The key in the pivot arm is correctly positioned for the first space when the space indicator needle is centered over the numeral 1 in the space indicator arc.

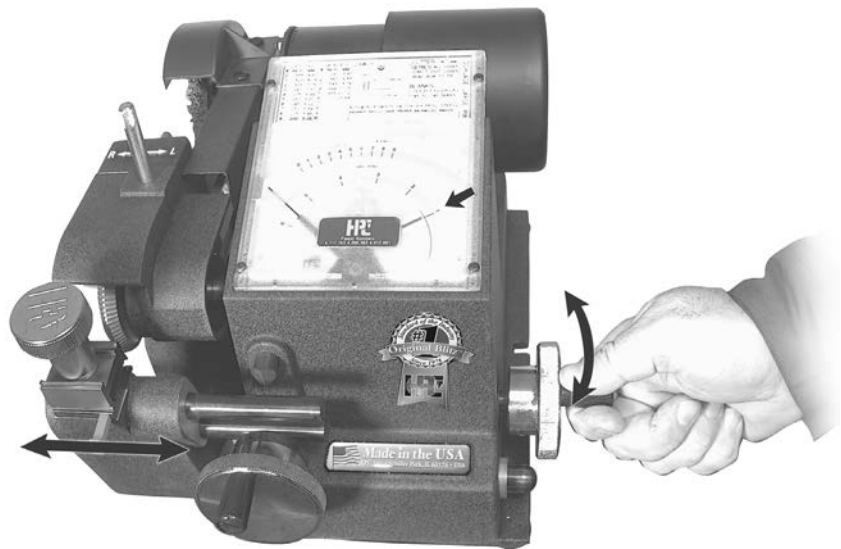



# 5.0

# CUTTING THE KEY

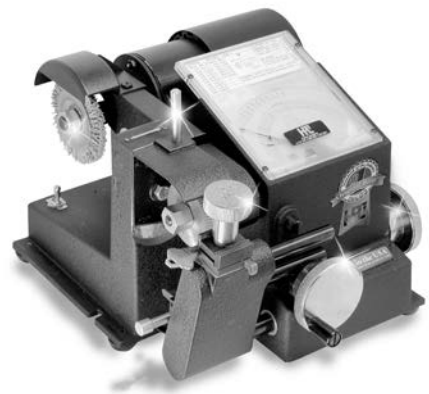

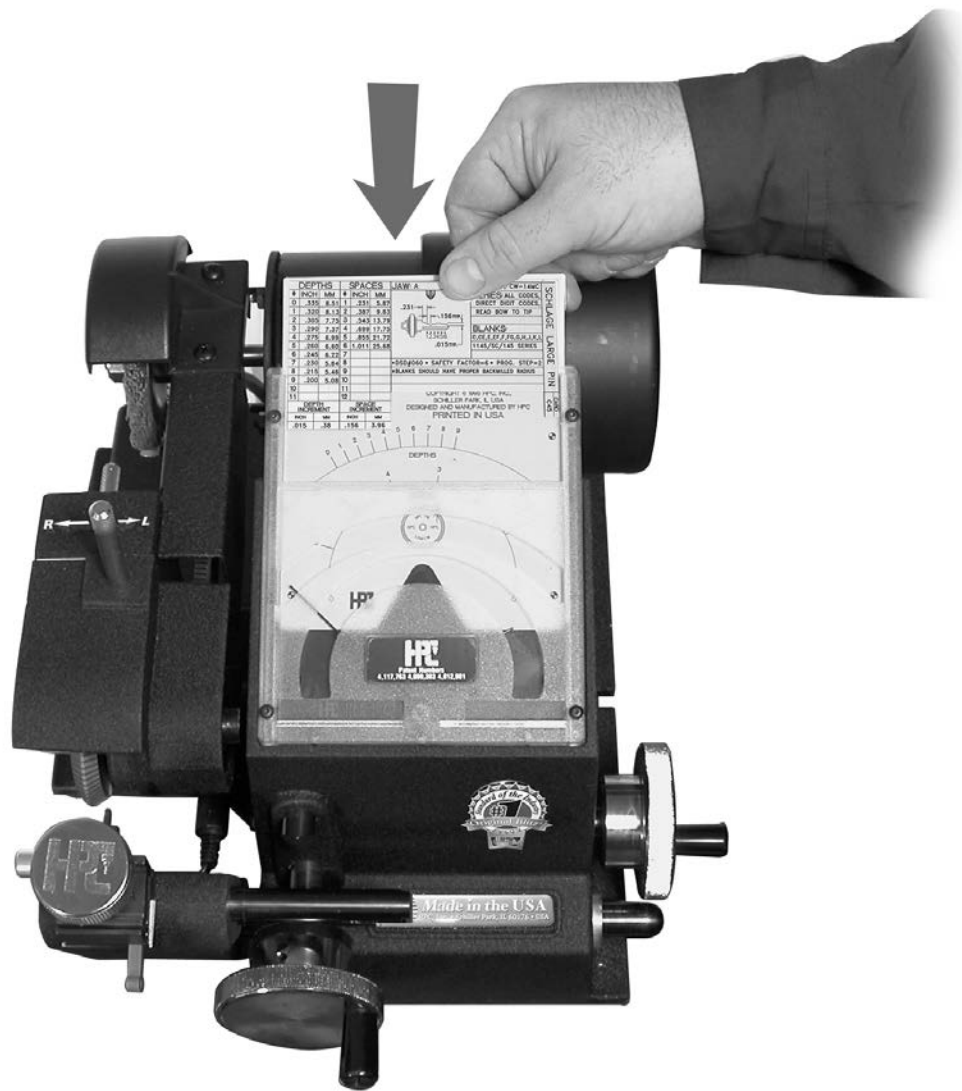

Select the correct Code Card and insert it beneath the lens as shown above.

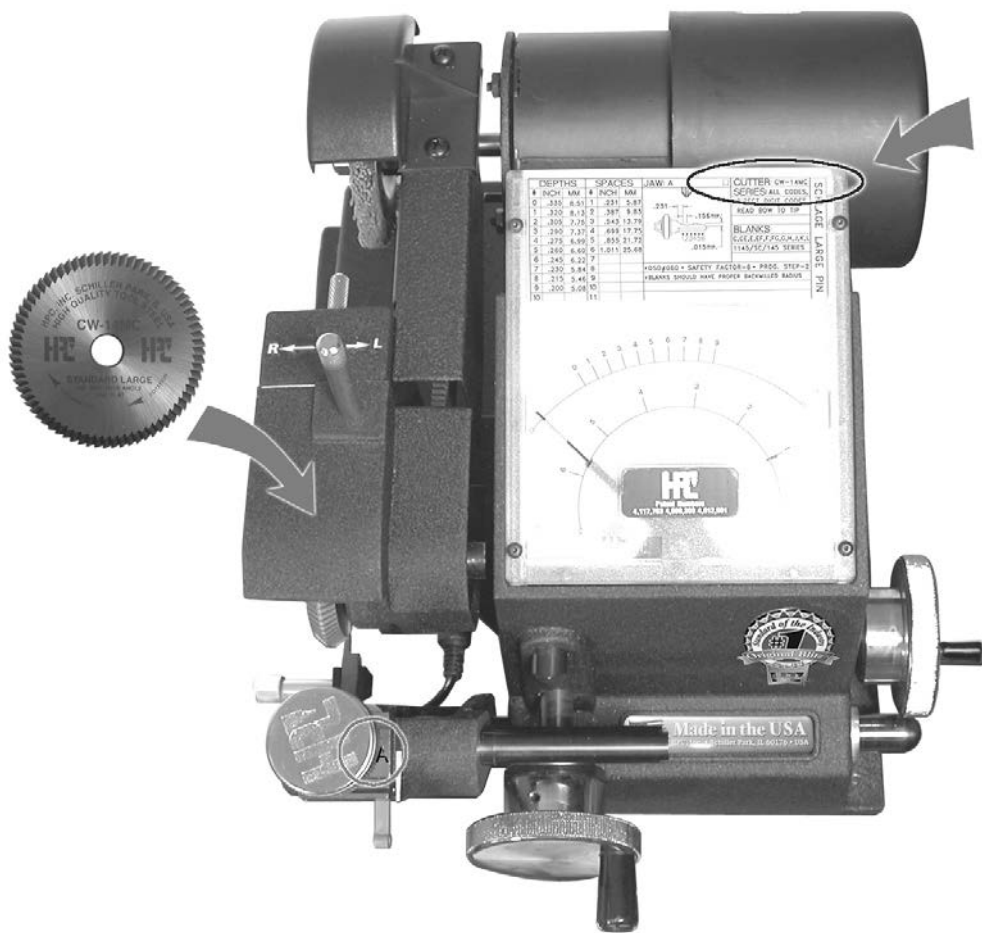

Change the cutter and jaw (if necessary) to those indicated on the Code Card.



For maximum clearance, and easy accessibility when inserting the key blank, rotate both of the crank knobs counter-clockwise.

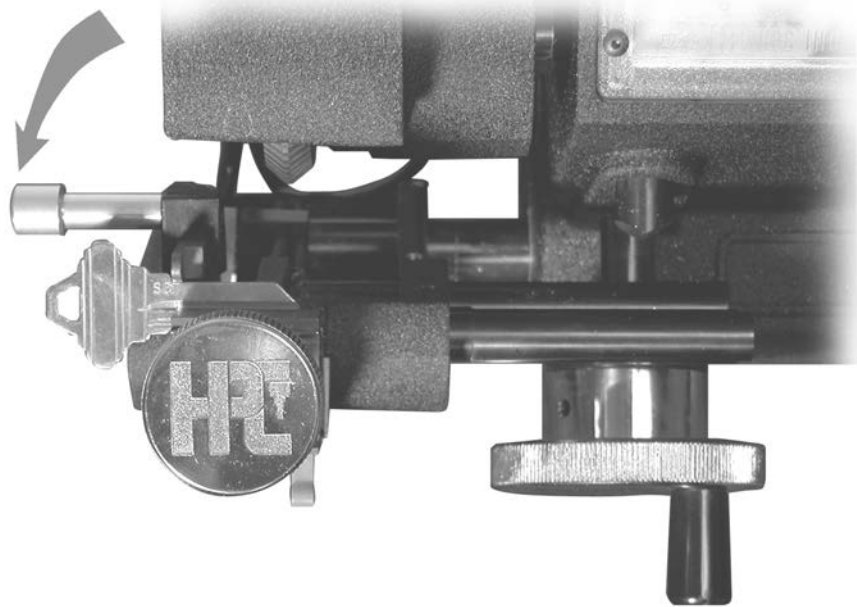

Gauge the key...

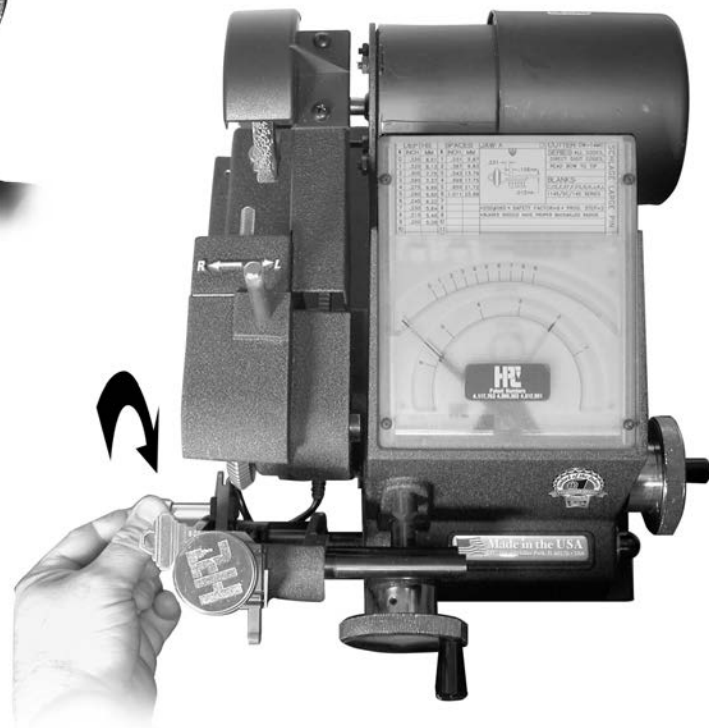
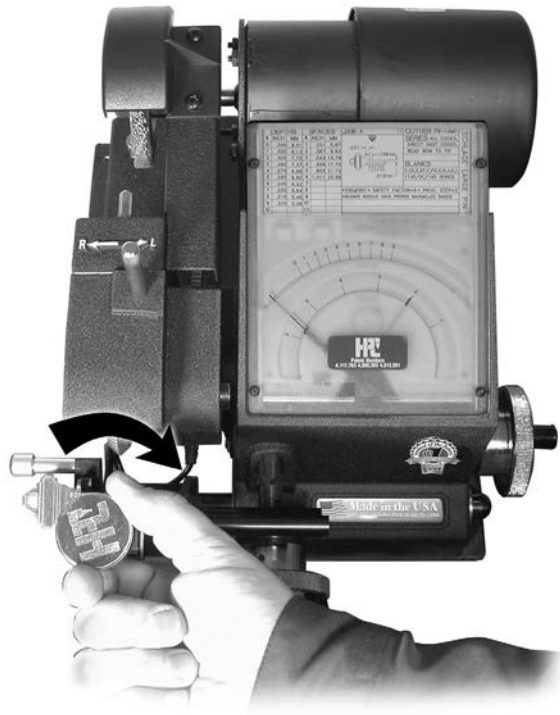

...and tighten the wing nut when the key is level. Then flip gauge down before starting to cut.

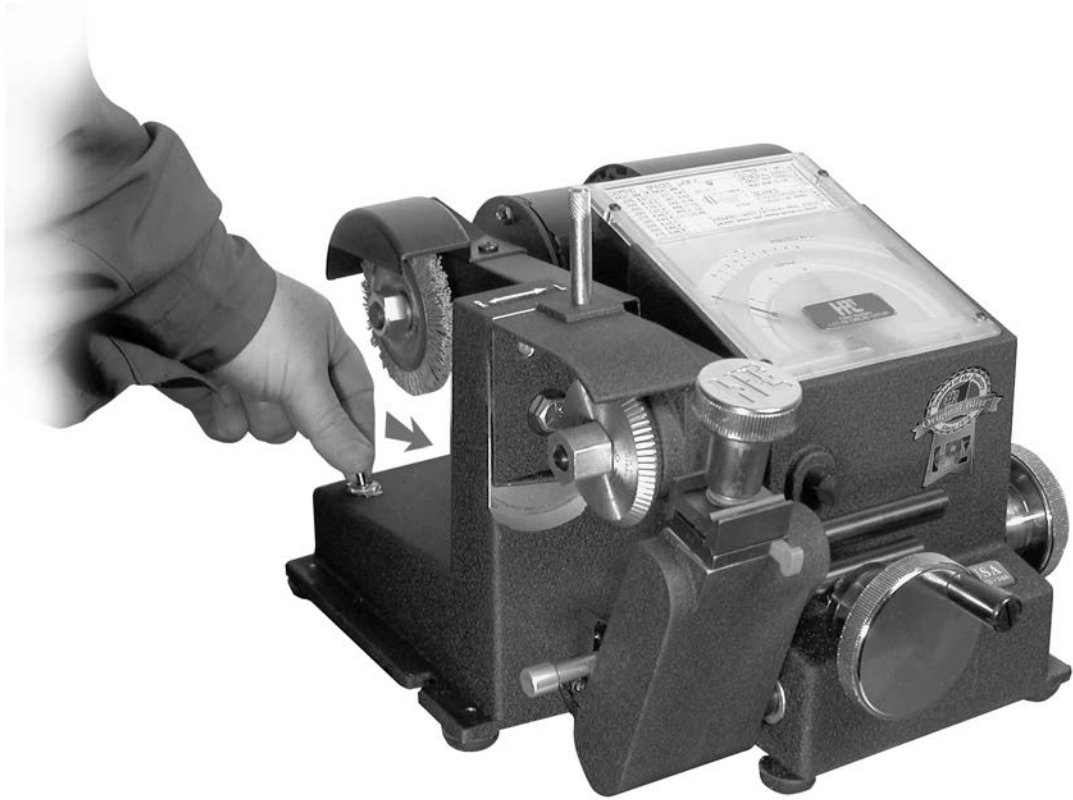

Turn machine "ON."

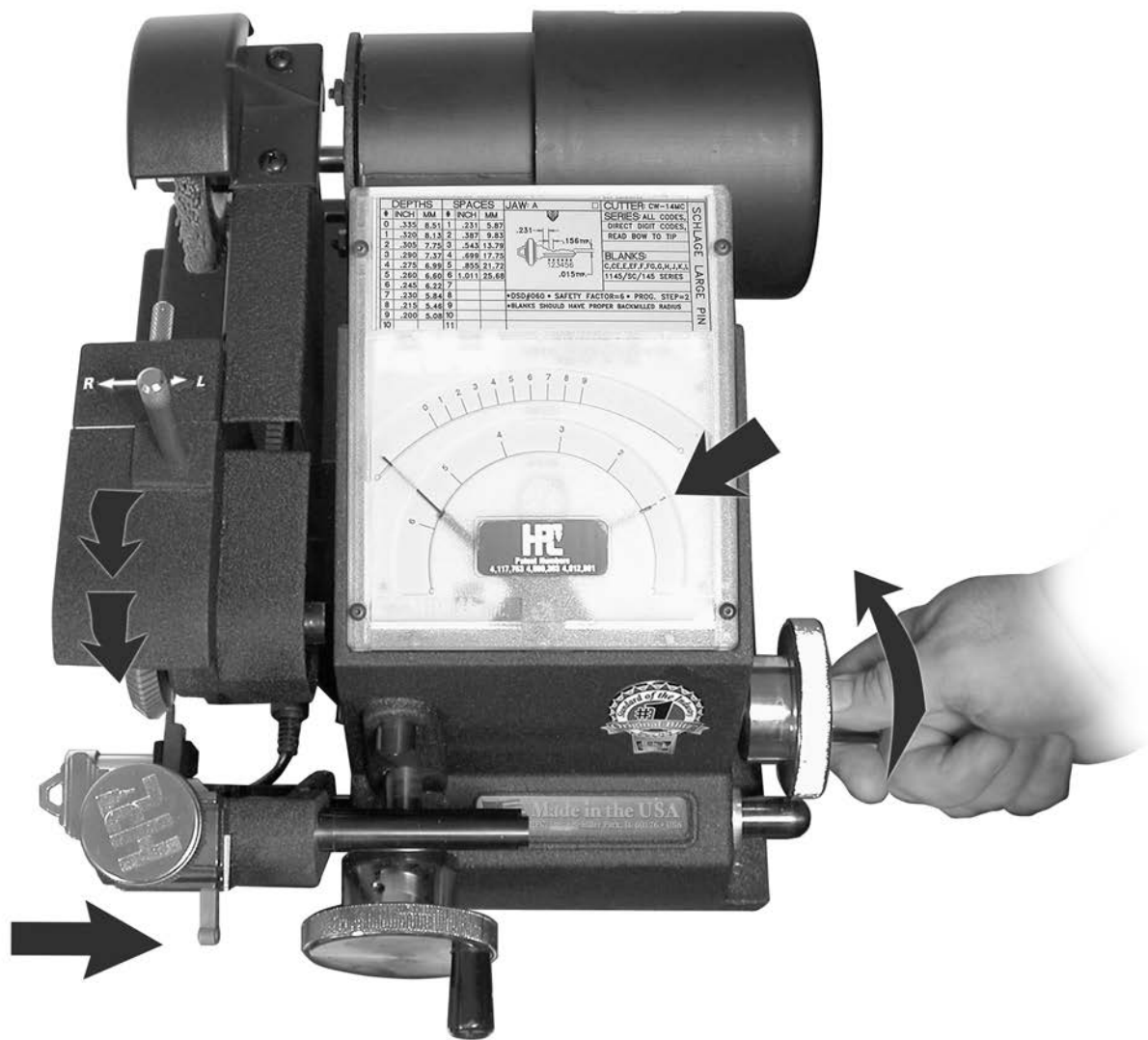

Rotate the lateral crank clockwise until the indicator lines up with the No. 1 space mark in the space window as indicated above.



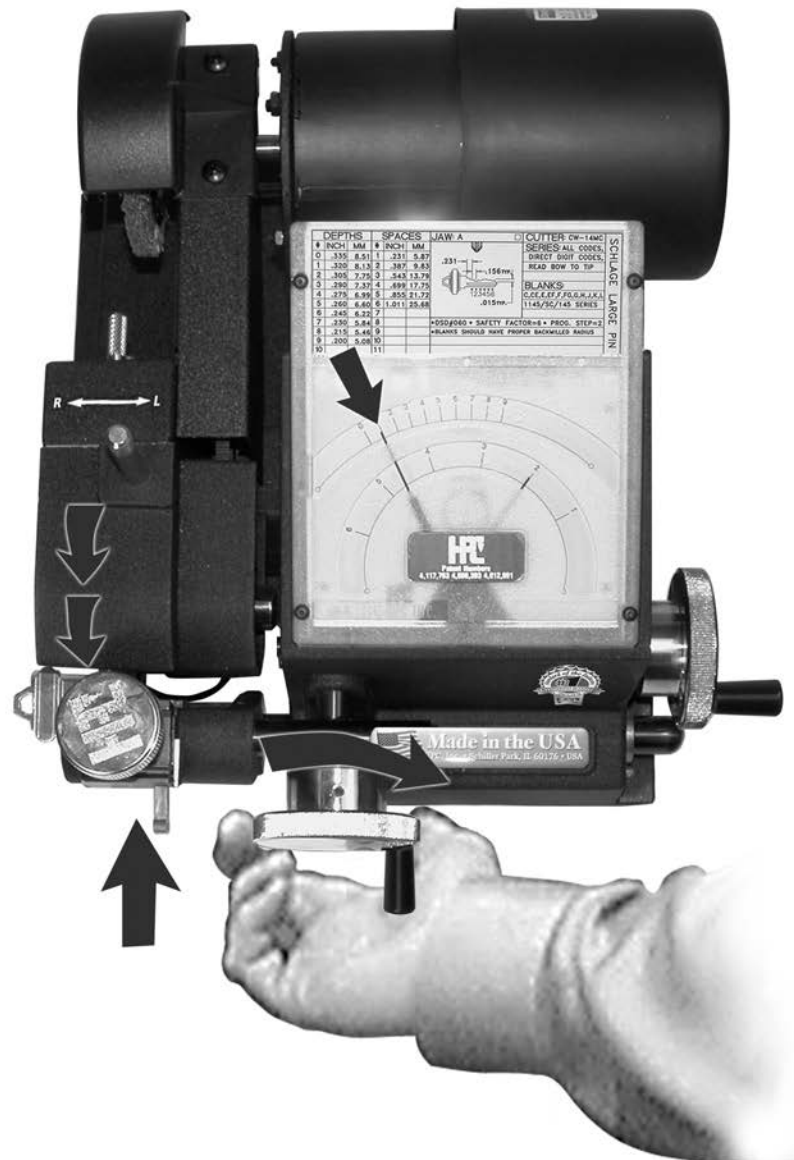

Slowly rotate the depth crank clockwise until the depth indicator is centered over the depth mark you wish to cut as shown in the upper depth window.

**Do NOT pass the mark!**

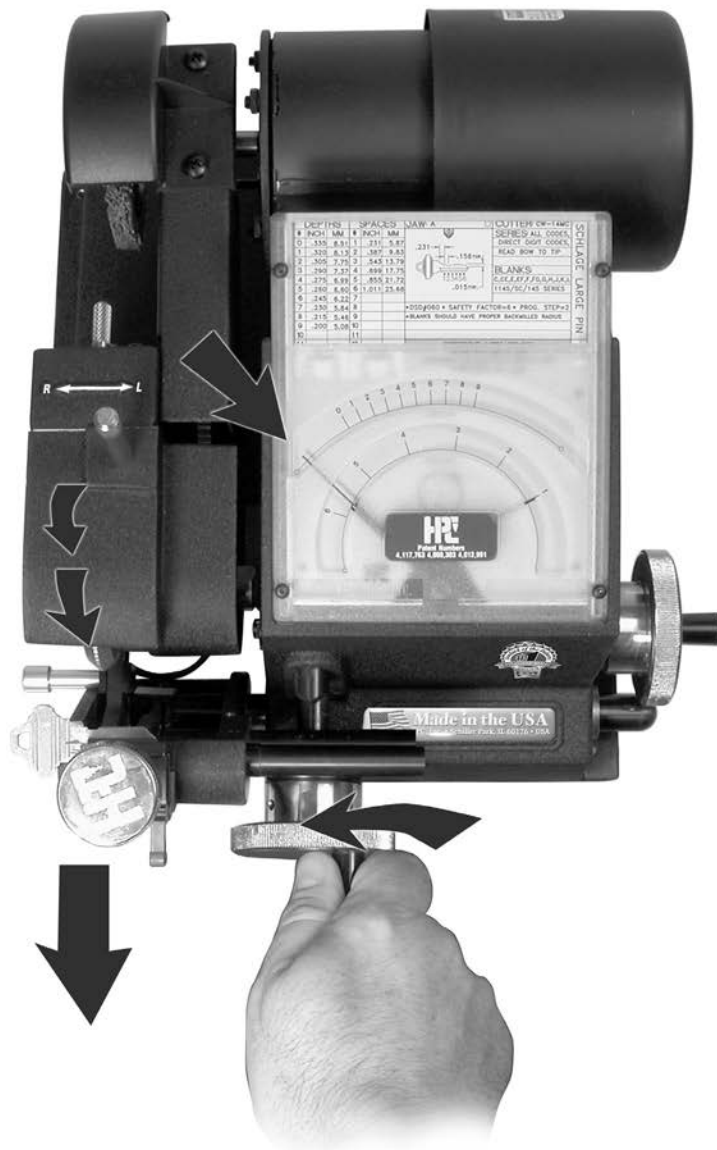

Now rotate the depth crank counter-clockwise (outward) until the spinning cutter is clear of the key blank.

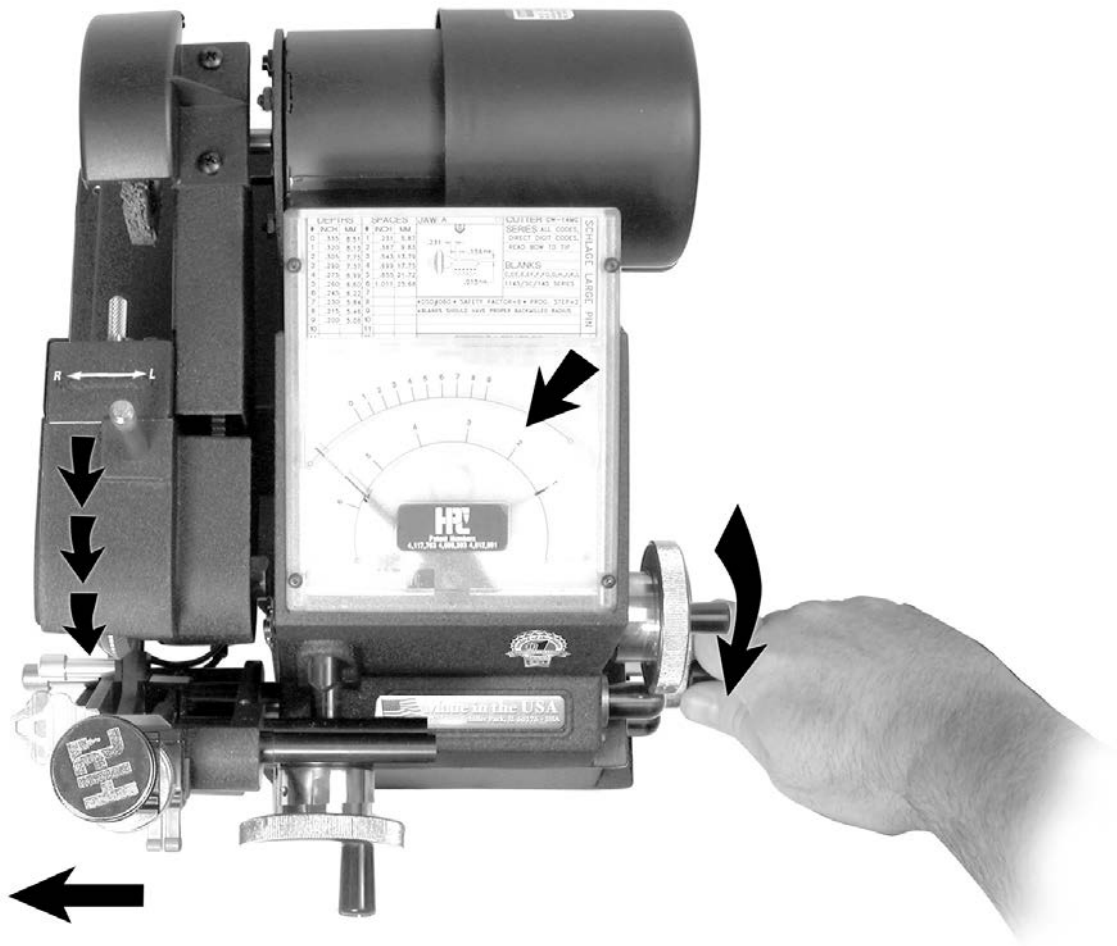

Rotate the lateral crank to the second space indicator.

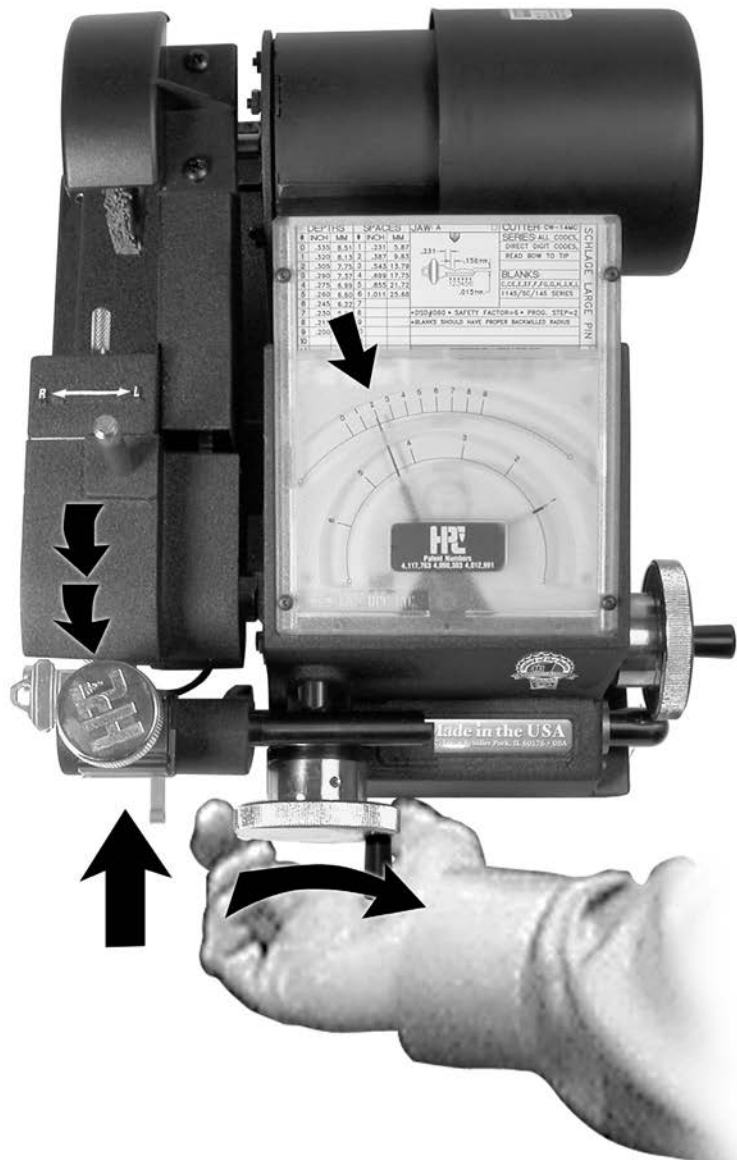

Slowly rotate the depth crank clockwise until the depth indicator is centered once more over the depth you wish to cut in this space position.

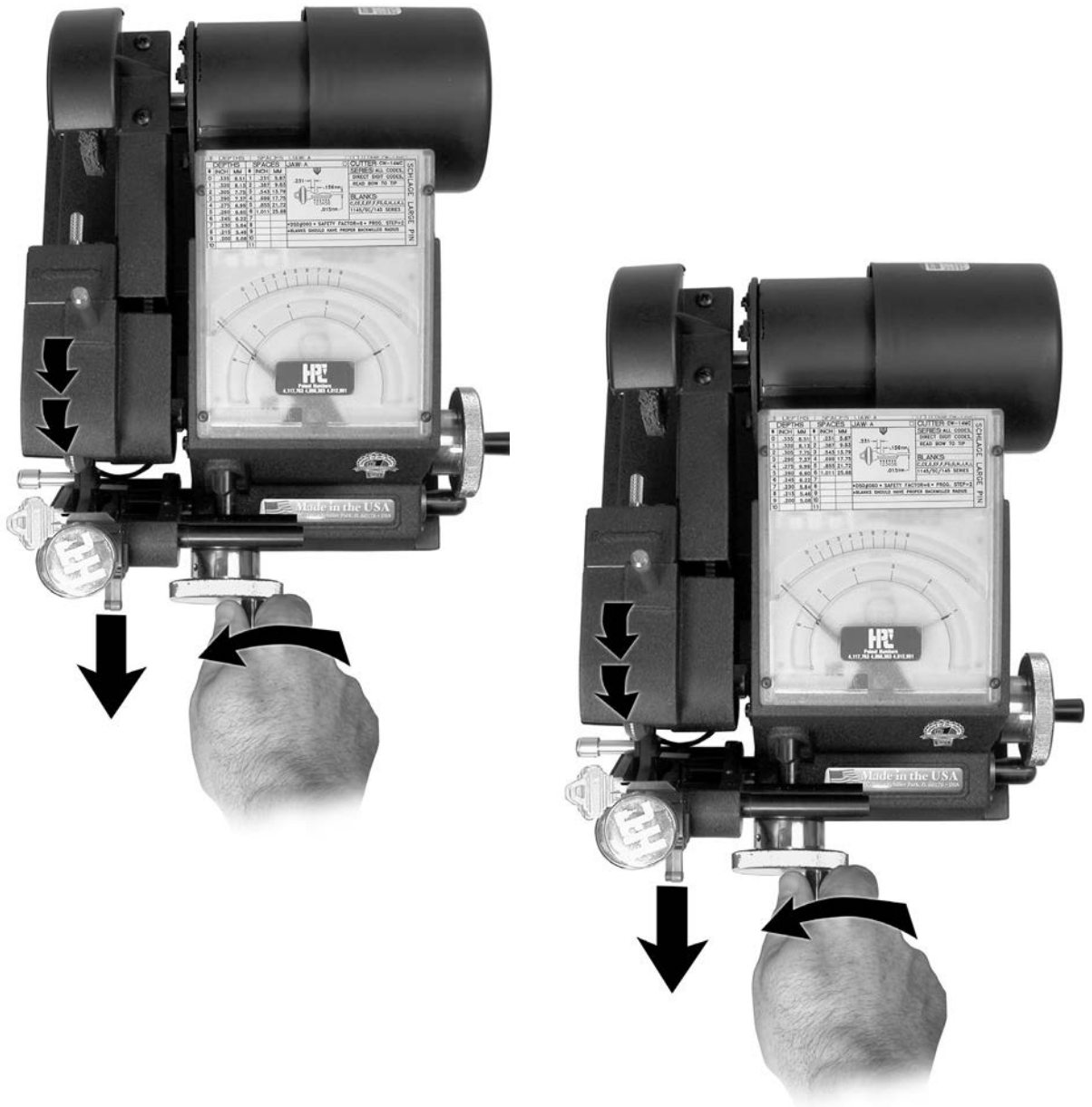

Continue the correct space and depth movements until all cuts are made from the head to the tip of the key.

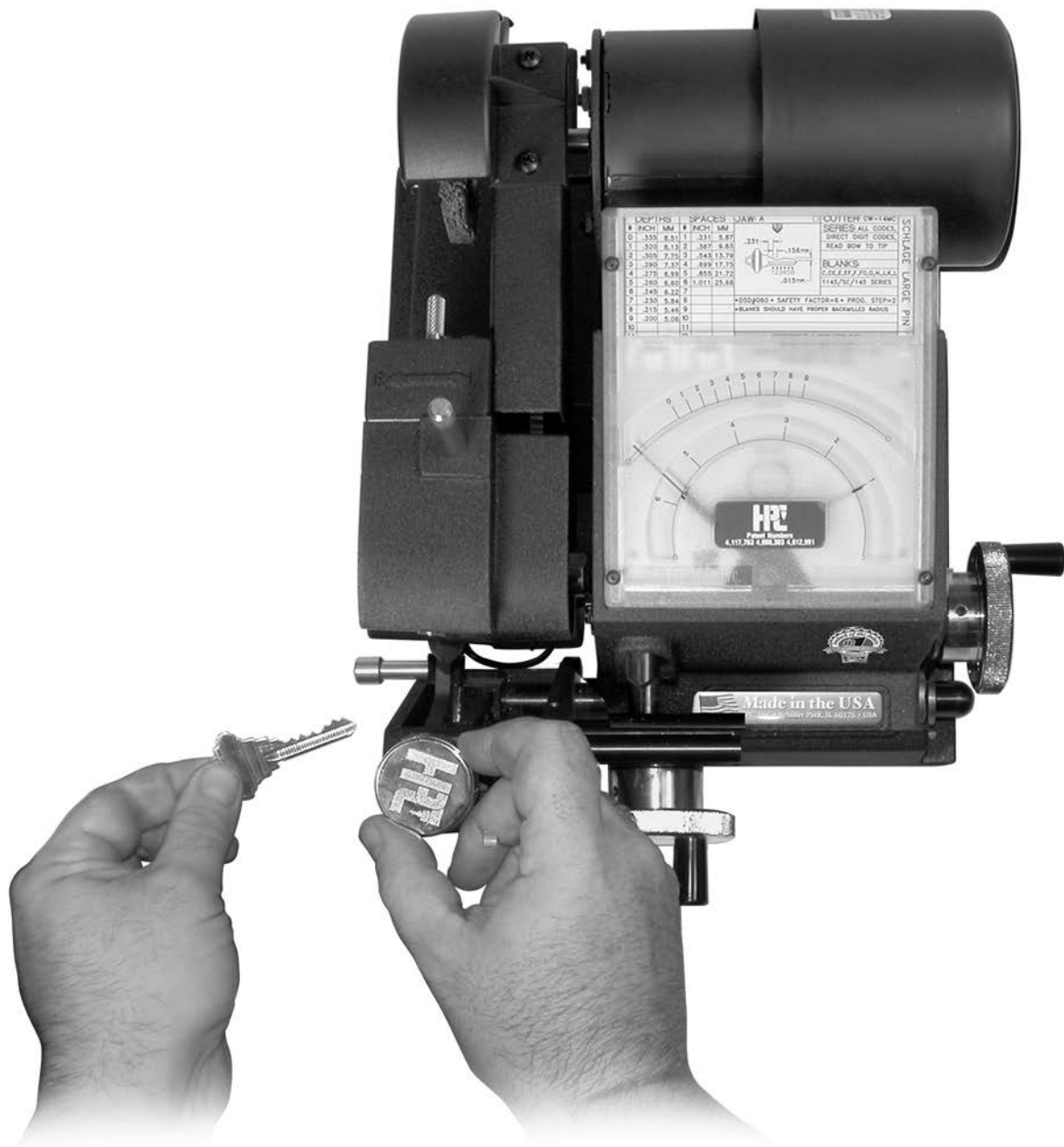

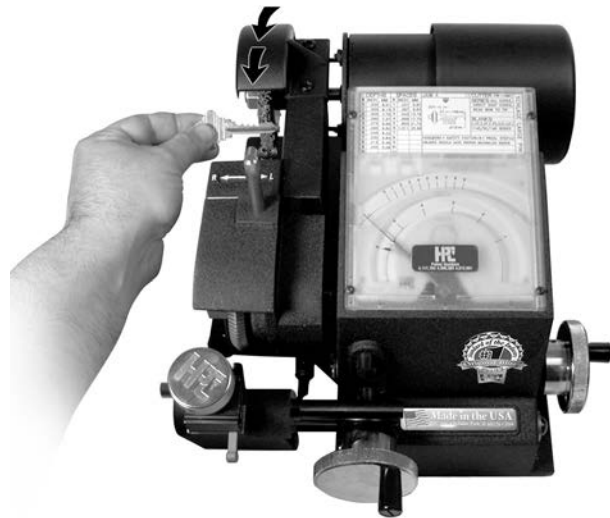
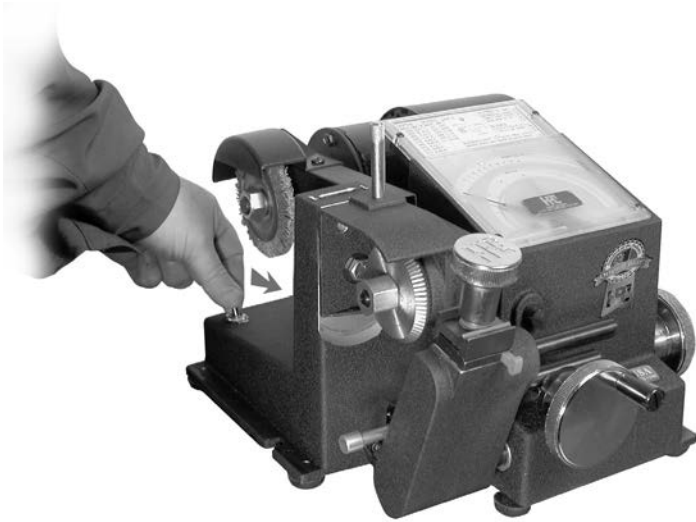

Turn motor back on to deburr key.

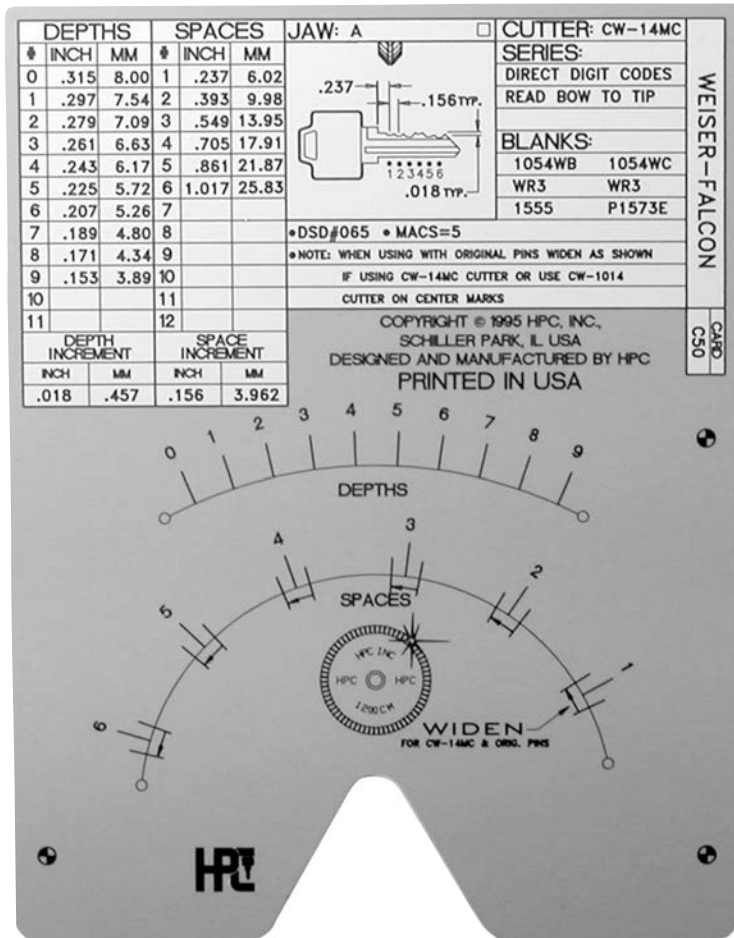

The following is only for keys that require widening as indicated on the code card.

When widening, start at the first small mark for each space and, while holding the depth crank, turn the lateral crank counter-clockwise from the first small widening mark through the center mark and stopping at the second small widening mark.

**Do NOT move back clockwise!**



# 6.0

# ANGLE CUT KEYS

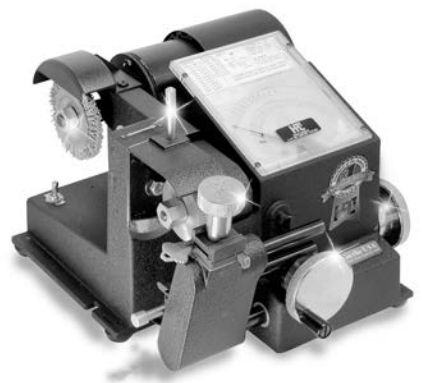

**CUTTING KEYS FOR MEDECO®  
STANDARD COMMERCIAL - CODE CARD NO. C36  
BIAXIAL - CODE CARD No. CSP3**



ONE OF THE UNIQUE FEATURES OF THIS MACHINE - is the ability to make cuts on an angle. By pulling outward on the spring loaded angle index pin the cutter head can be swiveled left or right. Be sure the index pin is re-locked into the cutter head before operating machine.

**•REQUIRED OPTIONAL EQUIPMENT**

An optional cutter and Jaw “C” are required to cut keys for commercial level Medeco®. This cutter Part No. CW-1012 and No. MJ-1 “Jaw C” may be added at a later date. Both parts are readily available from your HPC distributor.

Biaxial keys only require the CW-1012 cutter, not the MJ-1 “Jaw C”.

\*Medeco® is a registered trademark of Medeco Security Locks, Inc.

# CUTTING KEYS FOR MEDECO® DECODING AND CUTTING THE KEY

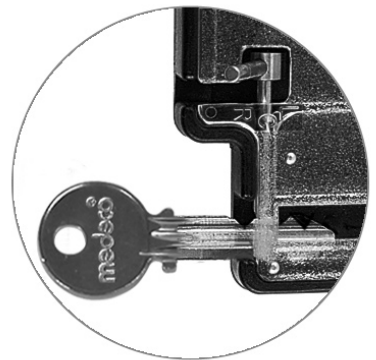
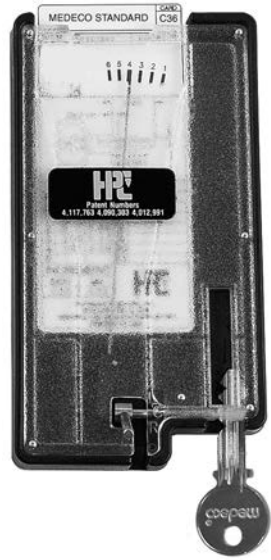
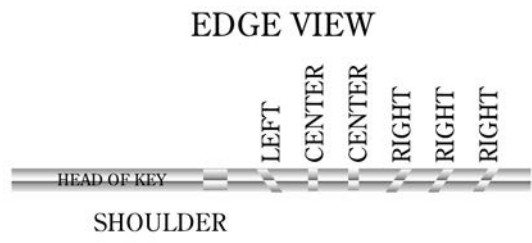
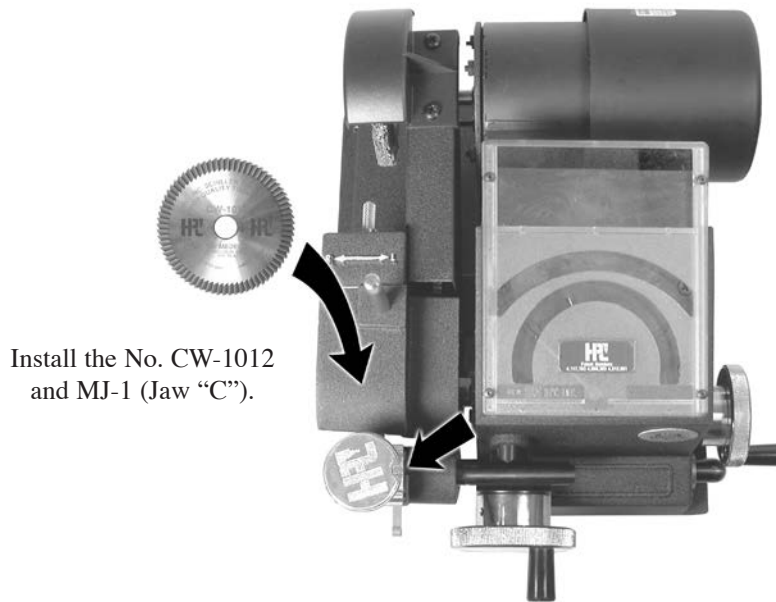

The depths and angles must be decoded prior to cutting the key. Depths can be measured with a knife-edge caliper, a key micrometer or with one of the special decoders commercially available. The HPC Pocket Sized Decoder, No. HKD-75 (pictured above), in addition to decoding depths and angles for Medeco® also contains an assortment of cards for other locks. Remember decoding devices are not designed to replace micrometers or calipers.

\*Medeco® is a registered trademark of Medeco Security Locks, Inc.

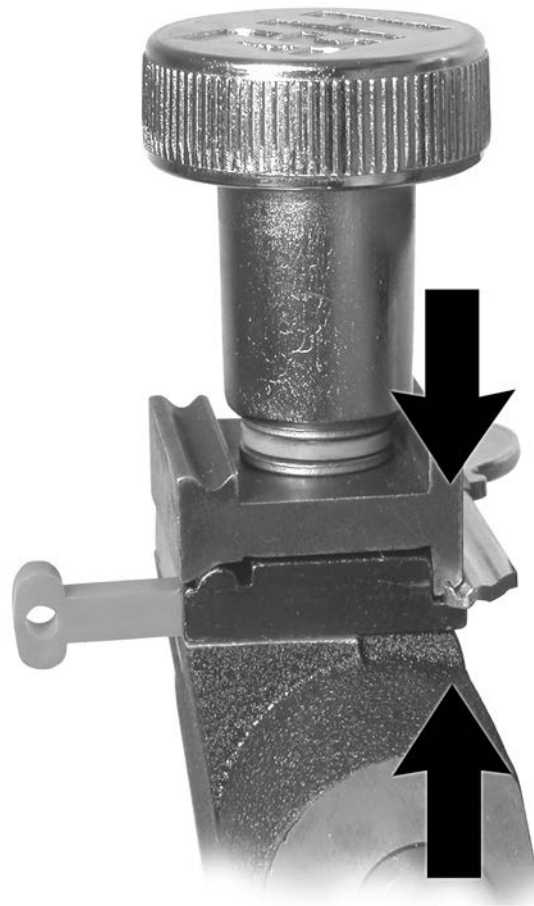
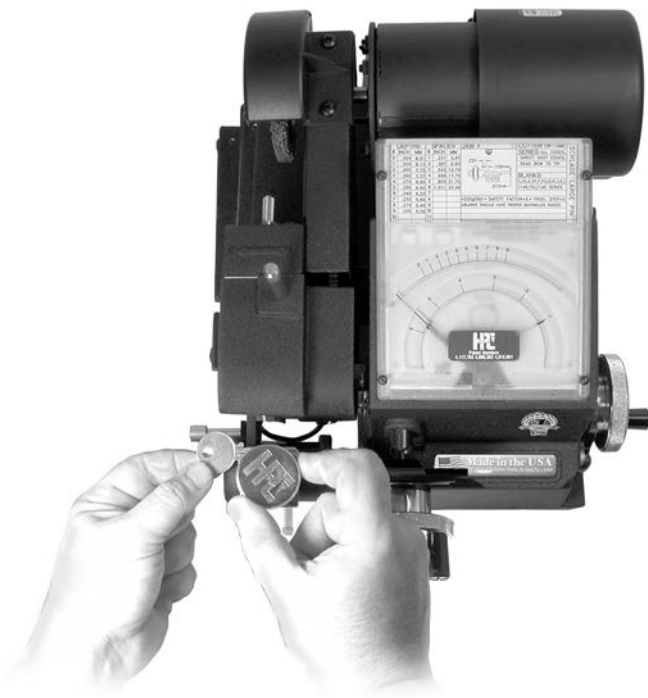

Gauge the key from the shoulder, making sure the key grooving and special jaw milling are nested together.

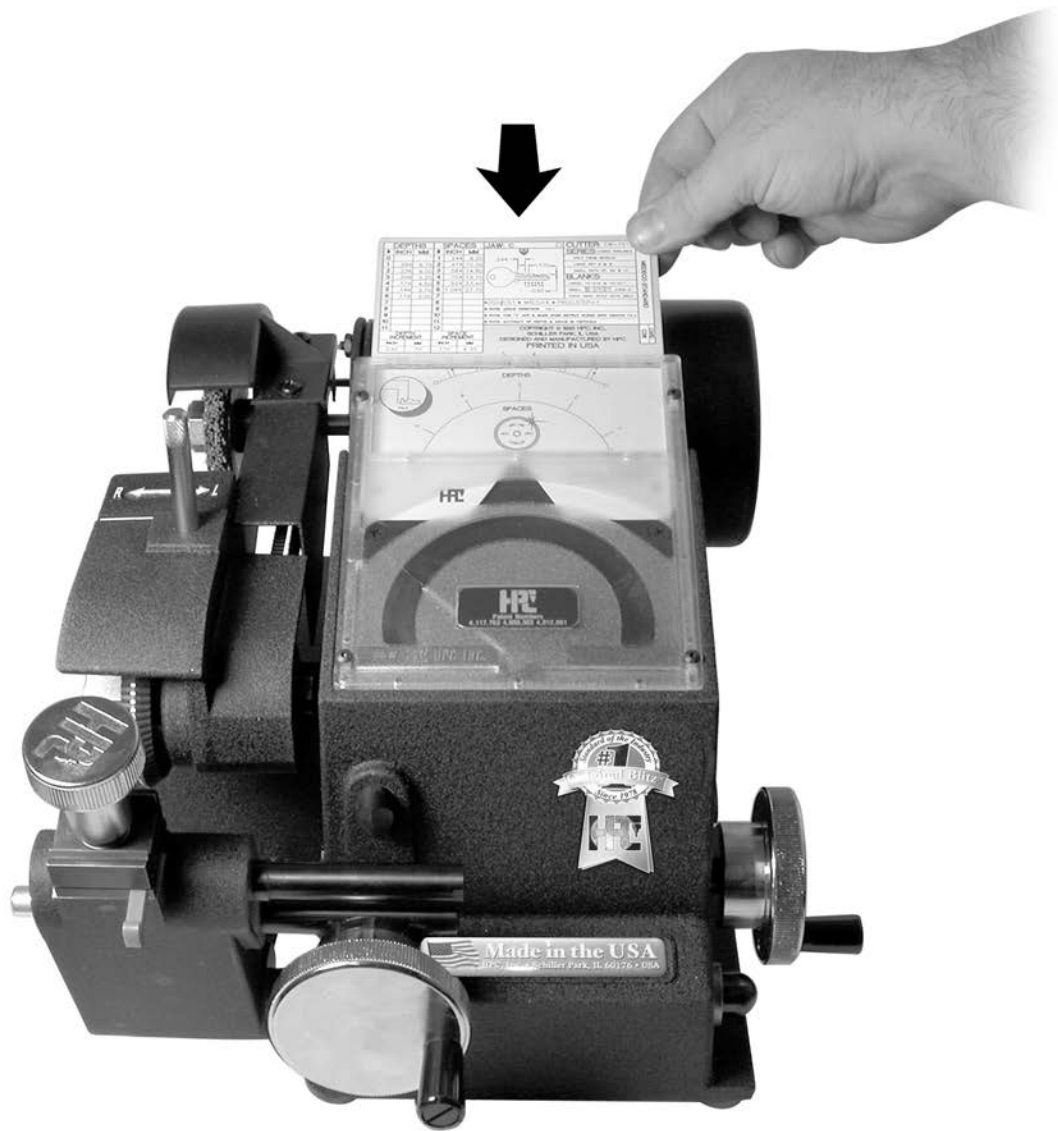

Insert Code Card No. C36 for Medeco®.

\*Medeco® is a registered trademark of Medeco Security Locks, Inc.



Blitz™  
No. 1200CMB



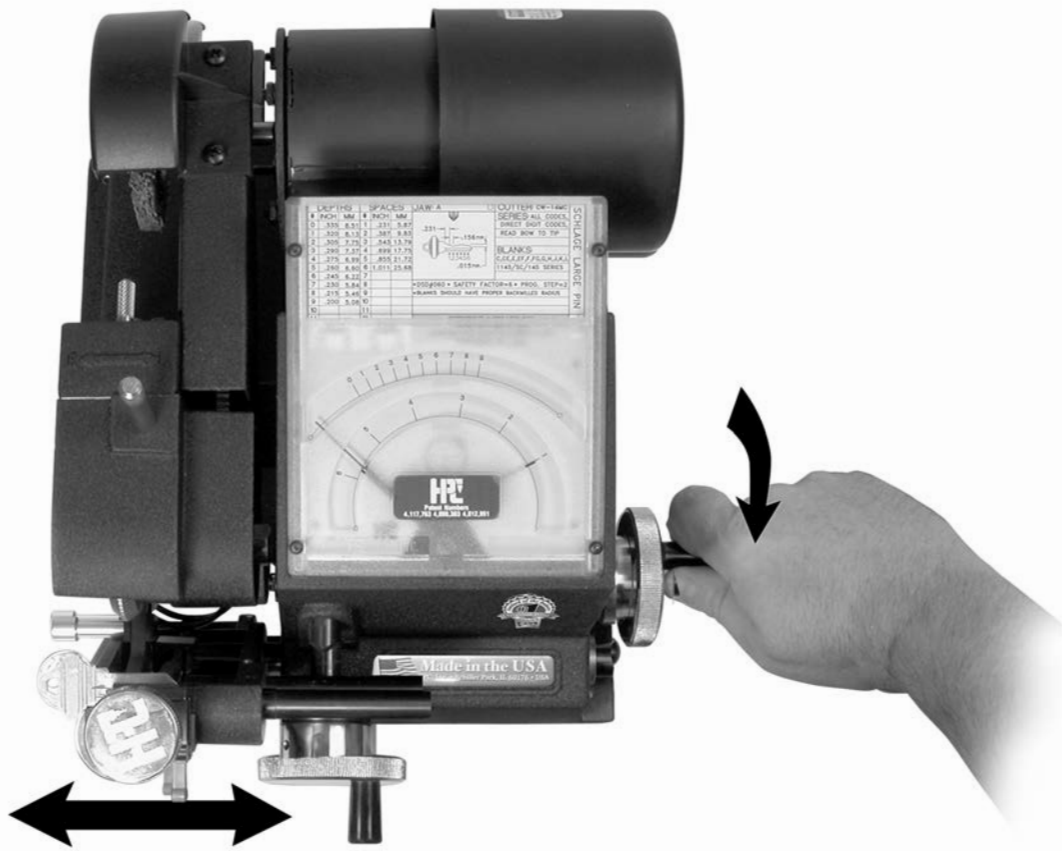

Turn the lateral crank as required to move key into the correct space positions for cuts with center angles. Cutter head is not swiveled for center cuts. Make all center angle cuts first.

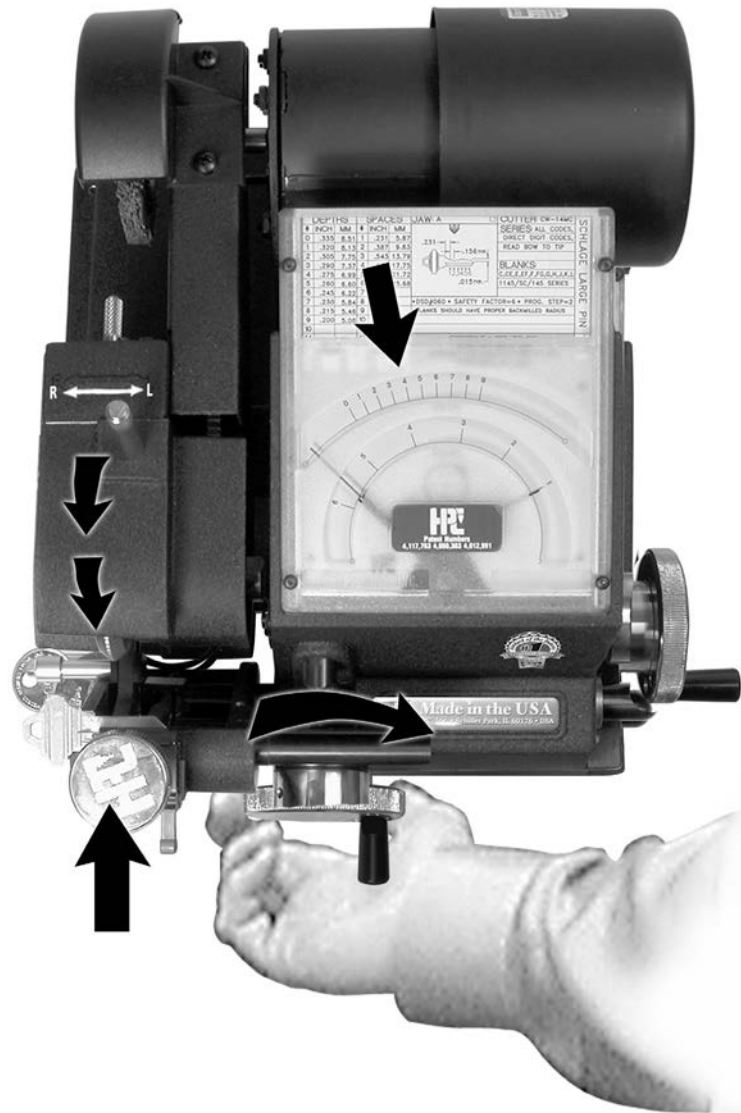

Cut first center cut.

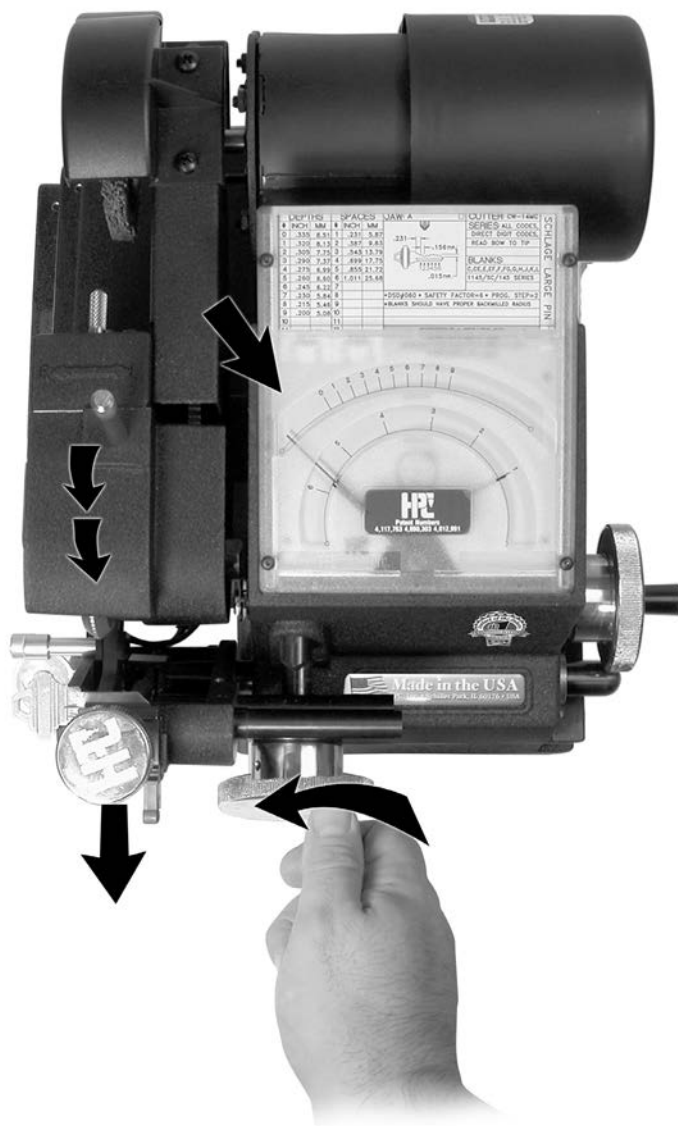

DEPTH	SPACES	SAW A	CUTTER ON-TIME
1-330	8.511	1-215	3.475
1-330	8.125	2-387	3.443
1-330	7.750	3-543	3.411
1-330	7.375	4-699	3.379
1-330	7.000	5-855	3.347
1-330	6.625	6-1011	3.315
1-330	6.250	7-1167	3.283
1-330	5.875	8-1323	3.251
1-330	5.500	9-1479	3.219
1-330	5.125	10-1635	3.187
1-330	4.750	11-1791	3.155
1-330	4.375	12-1947	3.123
1-330	4.000	13-2103	3.091
1-330	3.625	14-2259	3.059
1-330	3.250	15-2415	3.027
1-330	2.875	16-2571	2.995
1-330	2.500	17-2727	2.963
1-330	2.125	18-2883	2.931
1-330	1.750	19-3039	2.899
1-330	1.375	20-3195	2.867
1-330	1.000	21-3351	2.835
1-330	0.625	22-3507	2.803
1-330	0.250	23-3663	2.771



Back off.



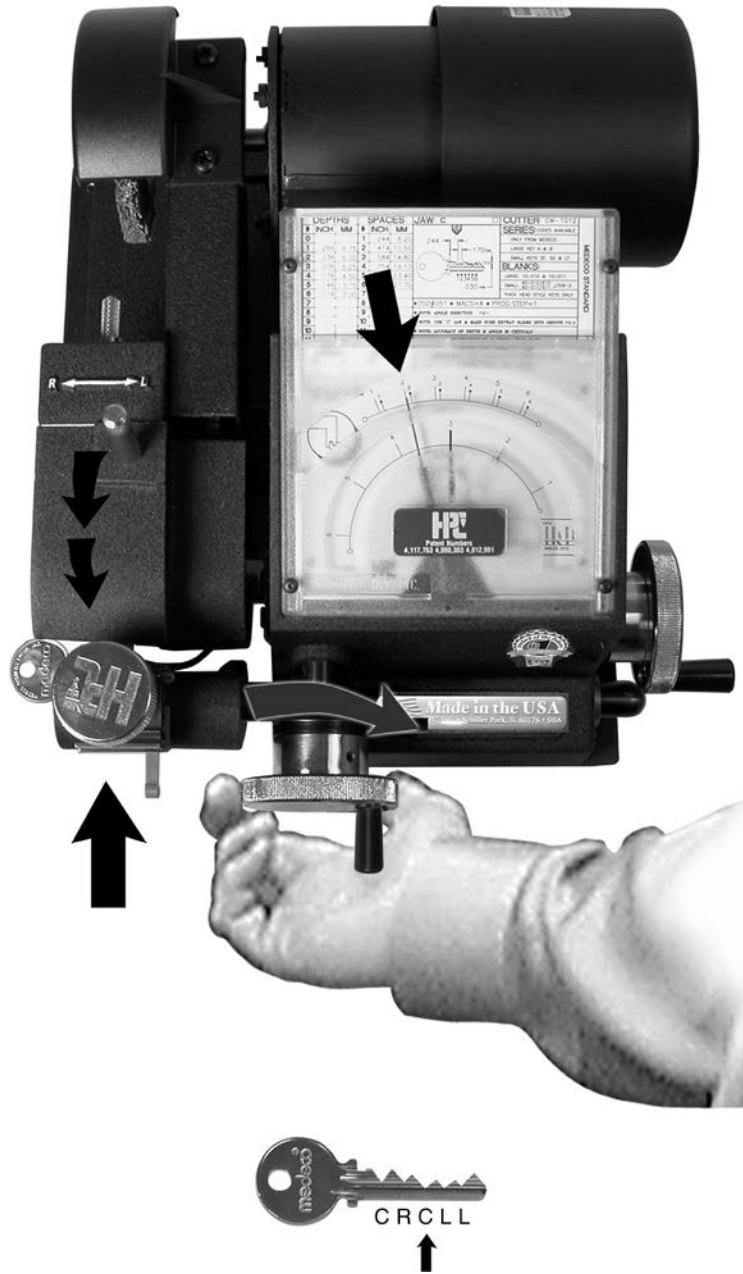

Move to next center angle cut and plunge.

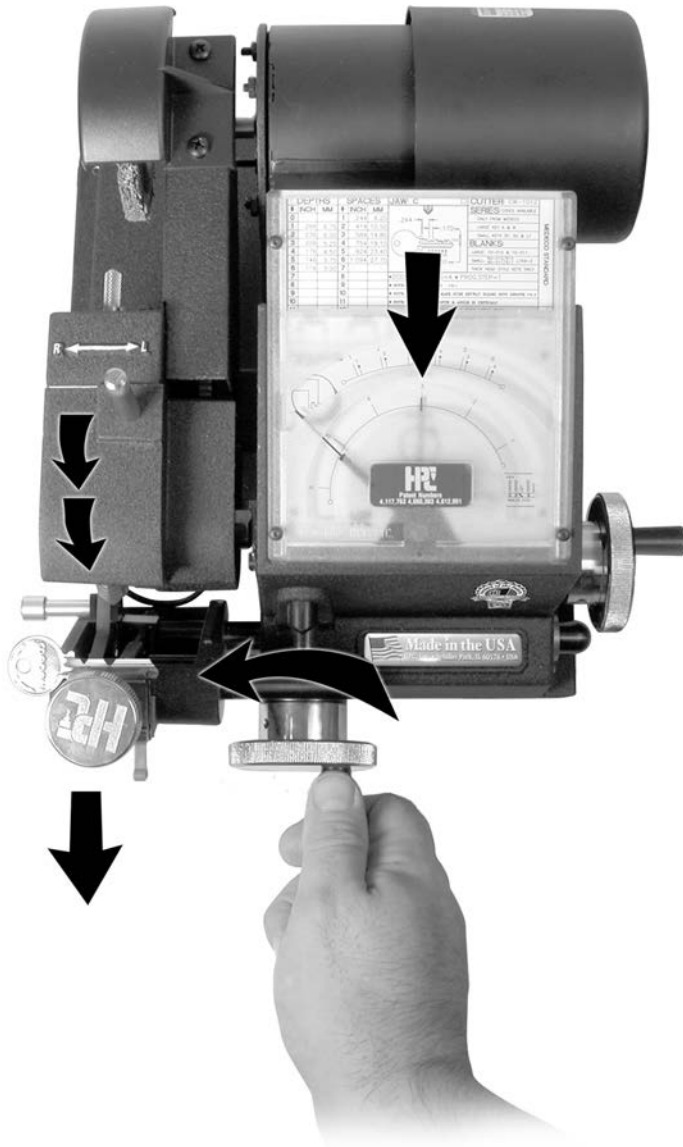

Back off.

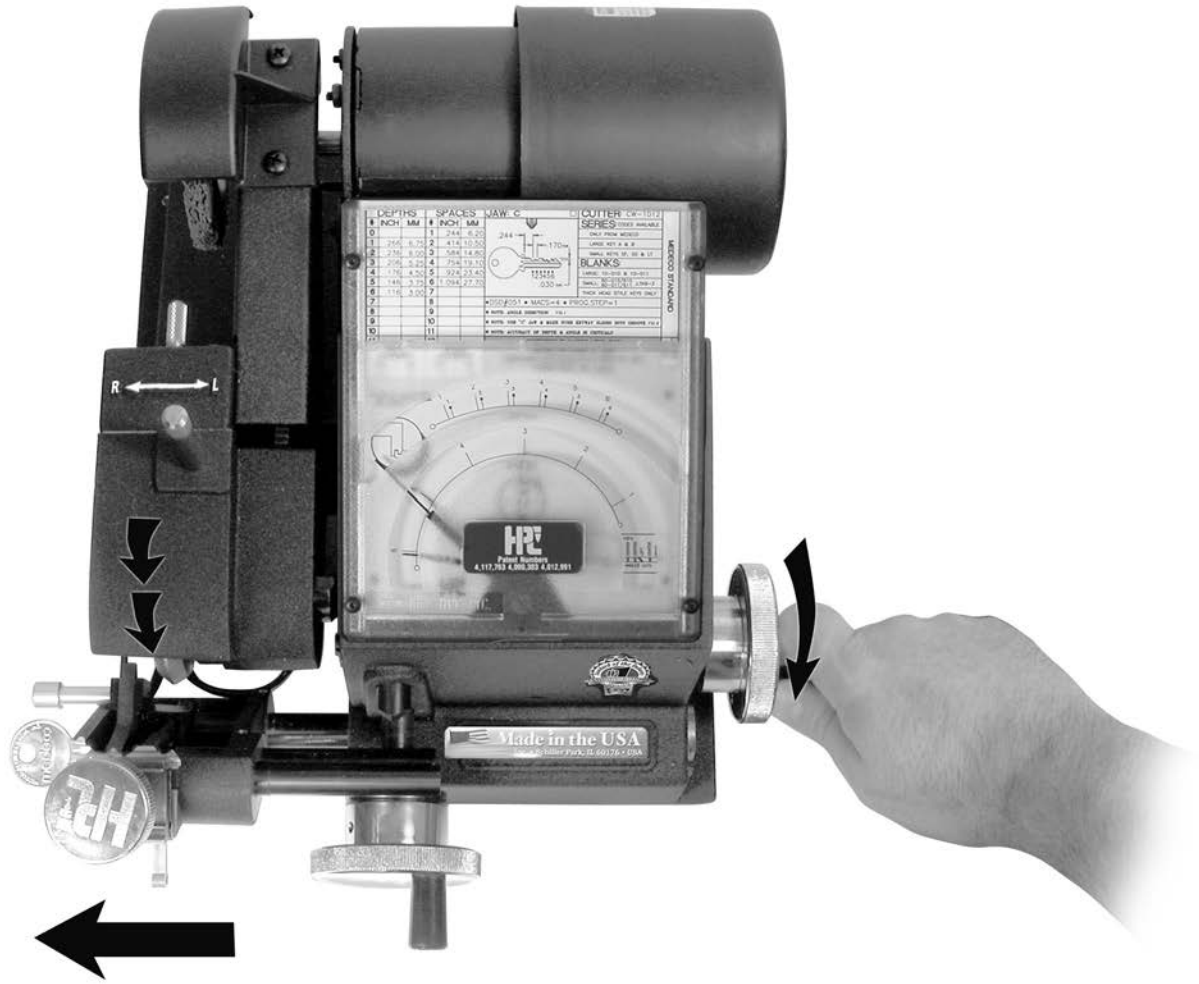

DEPTHS		SPACES		LAW G		CUTTER	
#	INCH	MM	#	INCH	MM	TYPE	SERIES
1	1.344	34.14	1	0.000	0.000	170	170
2	2.688	68.28	2	0.000	0.000	170	170
3	4.032	102.42	3	0.000	0.000	170	170
4	5.376	136.56	4	0.000	0.000	170	170
5	6.720	170.70	5	0.000	0.000	170	170
6	8.064	204.84	6	0.000	0.000	170	170
7	9.408	238.98	7	0.000	0.000	170	170
8	10.752	273.12	8	0.000	0.000	170	170
9	12.096	307.26	9	0.000	0.000	170	170
10	13.440	341.40	10	0.000	0.000	170	170
11	14.784	375.54	11	0.000	0.000	170	170
12	16.128	409.68	12	0.000	0.000	170	170
13	17.472	443.82	13	0.000	0.000	170	170
14	18.816	477.96	14	0.000	0.000	170	170
15	20.160	512.10	15	0.000	0.000	170	170

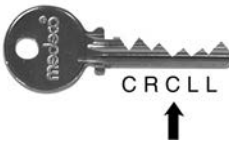

Move away from cutter.

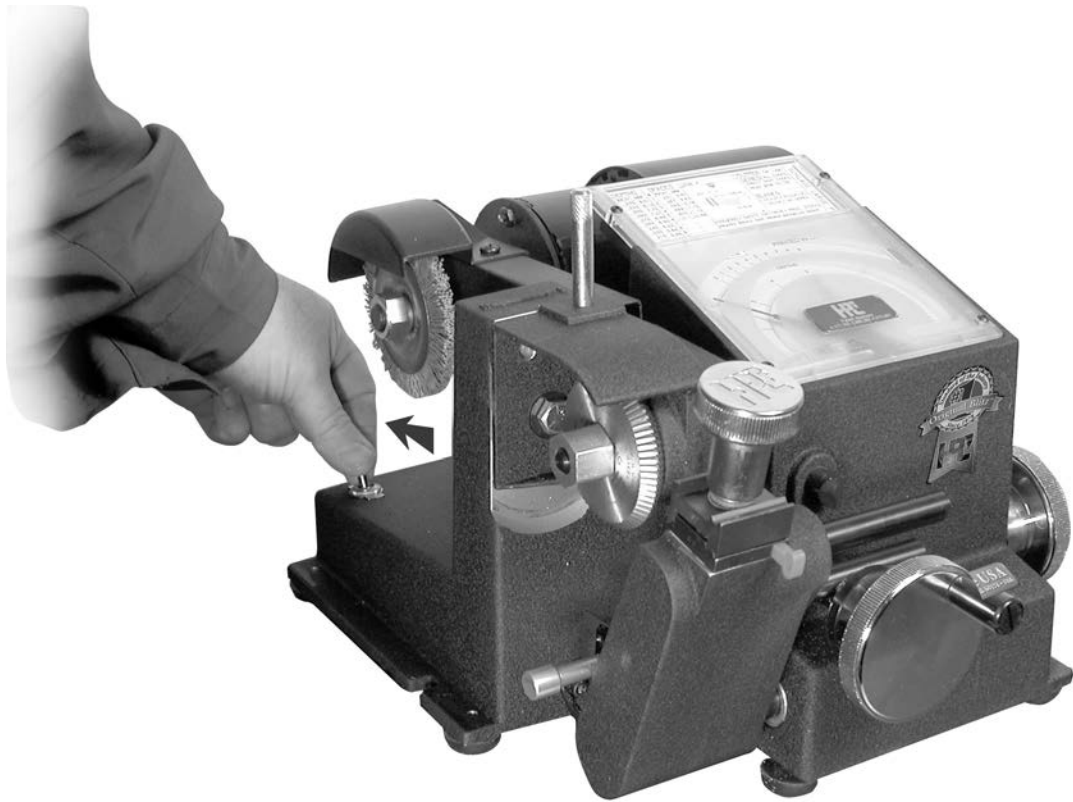

Turn off the machine.

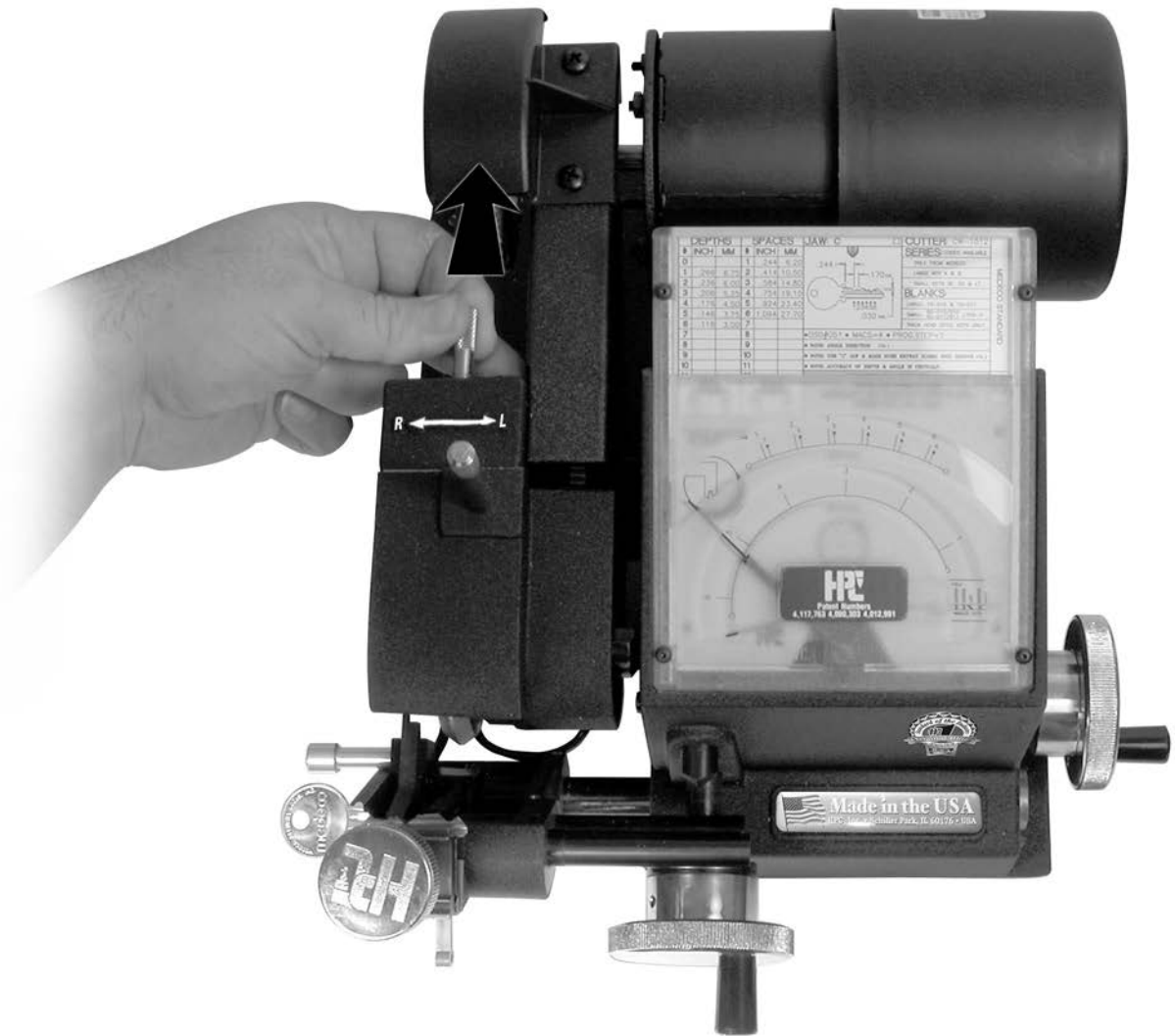

Pull outward on angle index pin.

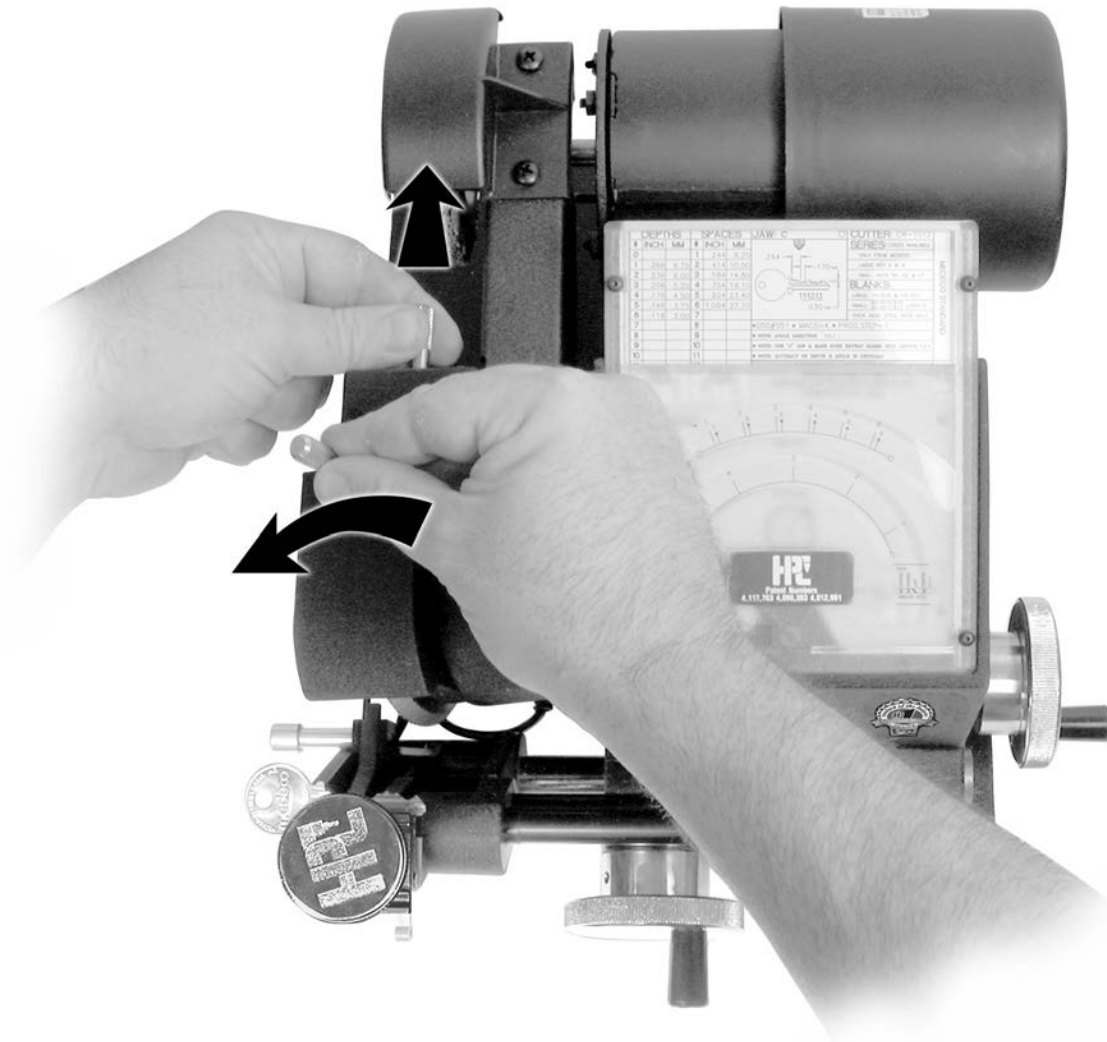

Swivel cutter head by the angle pivot pin, as indicated by the arrows.

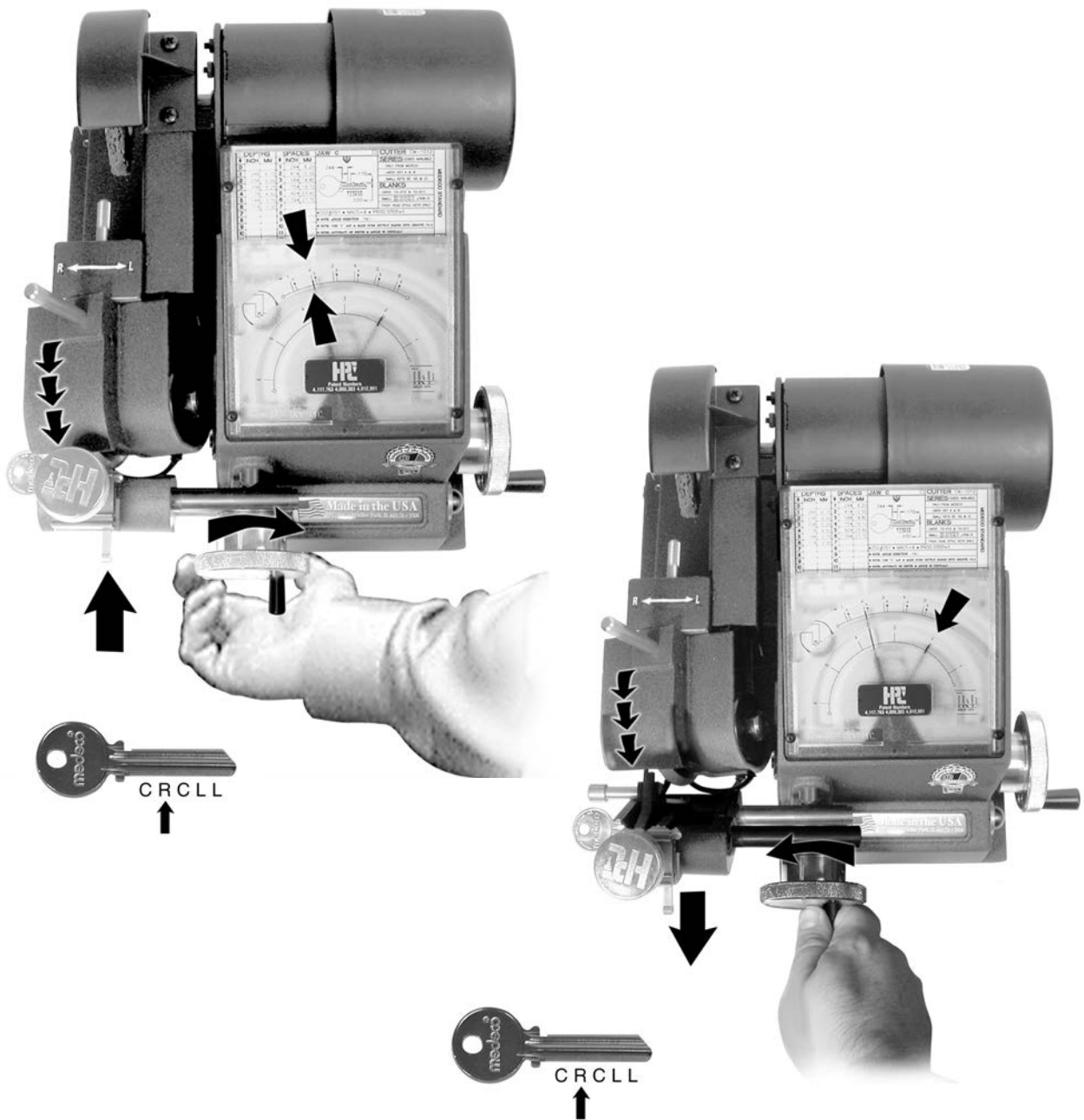

Be sure the index pin is relocked into the cutter head before operating. Make all right angle cuts at this time.

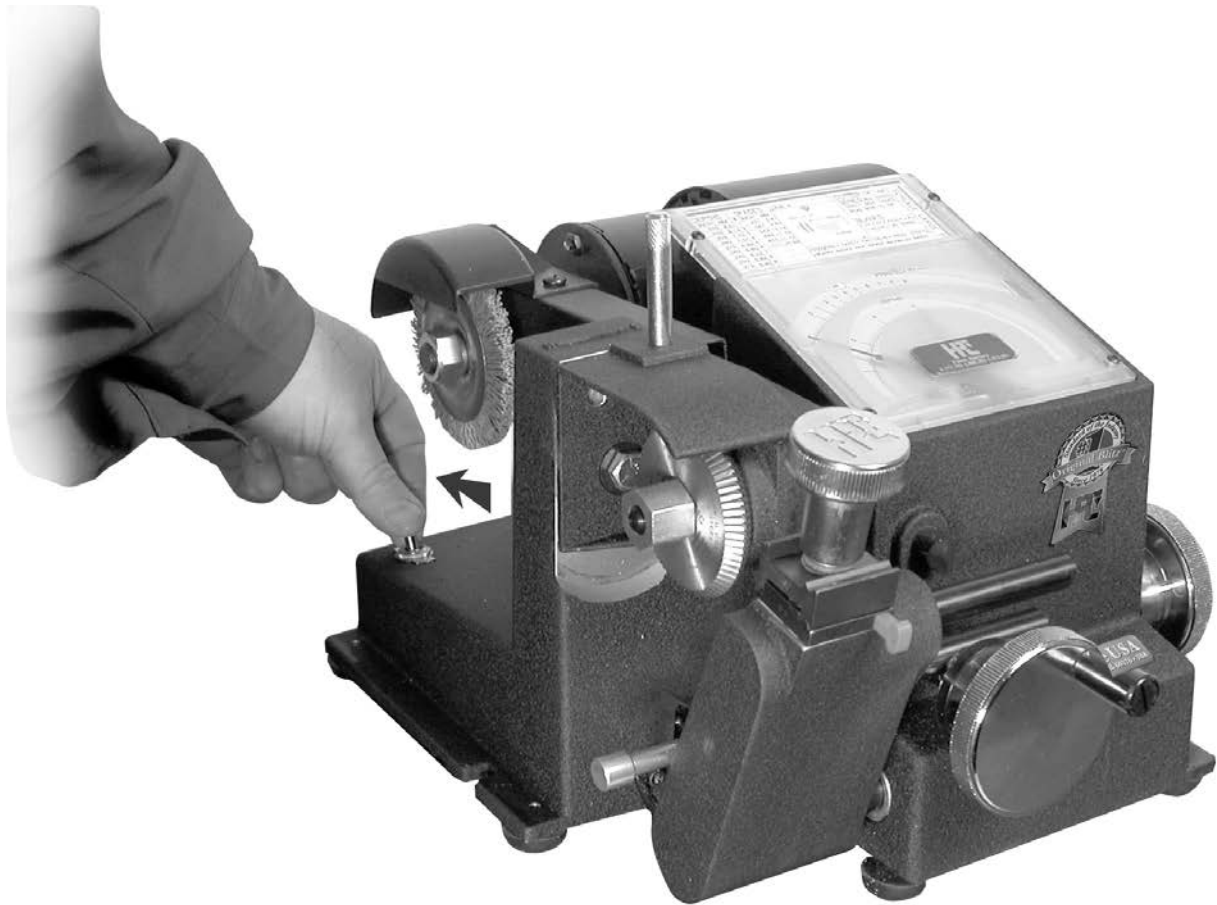

Then turn off the machine.



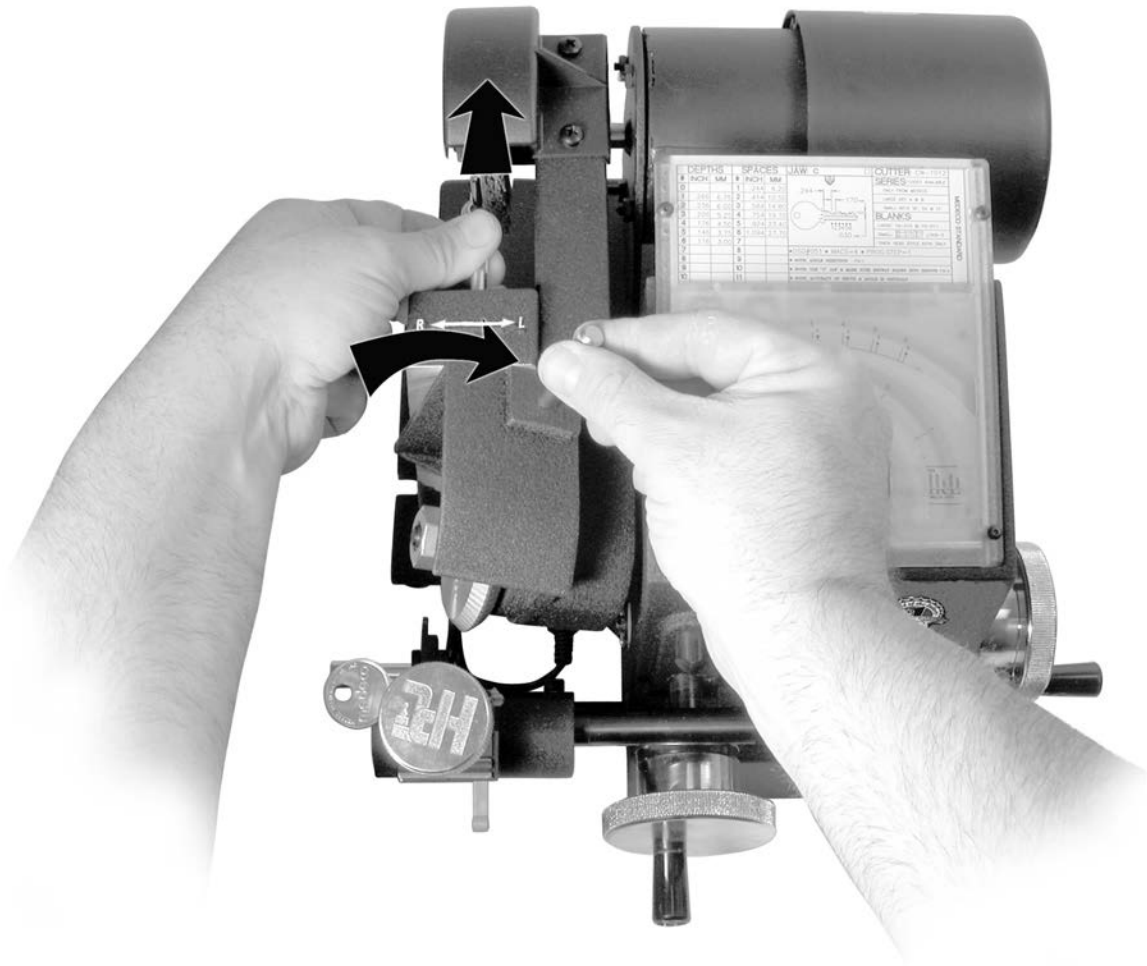

Repeat the same procedure for left angle cuts.

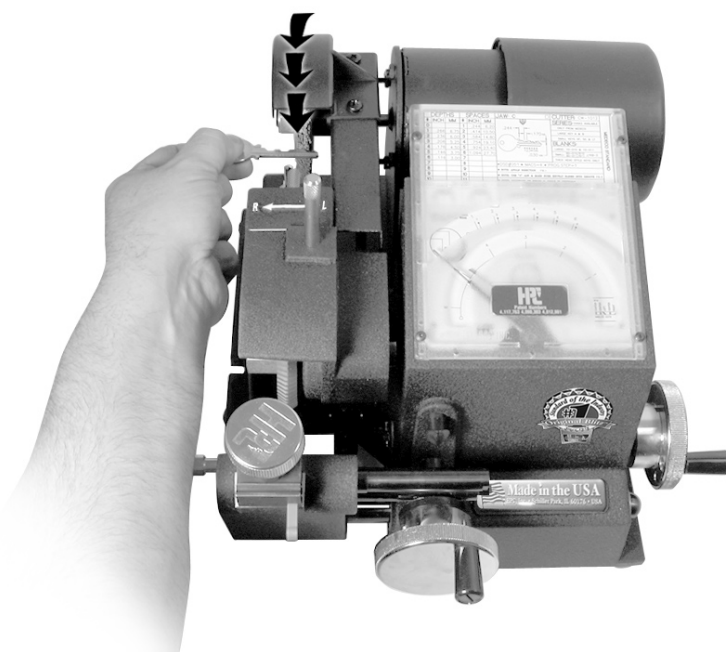
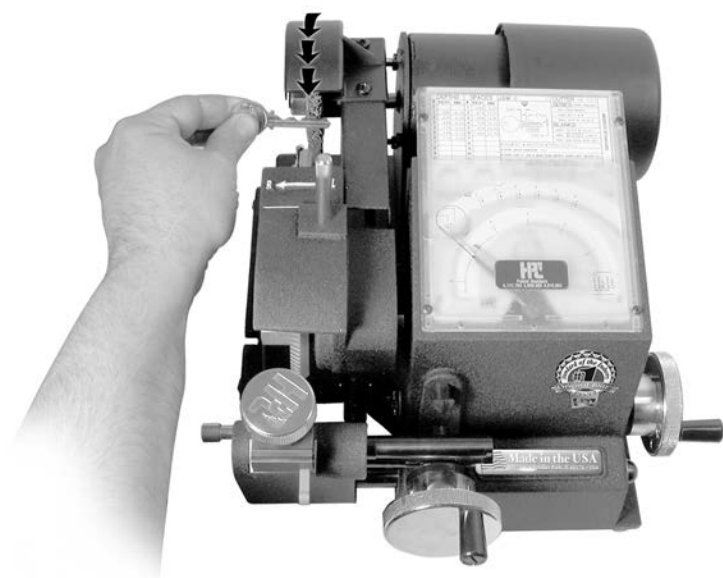

Be sure to brush Medeco<sup>®</sup> keys exceptionally clean and free of all burrs. Hold the cut key so that the rotation of the deburring brush sweeps the burrs out and away from the cut.

\*Medeco<sup>®</sup> is a registered trademark of Medeco Security Locks, Inc.

# 7.0

# RE-CALIBRATION OF DEPTH

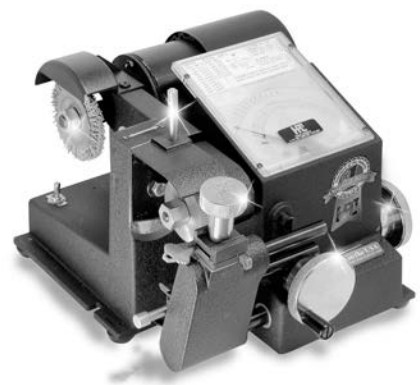

## **ATTENTION: PLEASE READ BEFORE PROCEEDING.**

### **RE-CALIBRATION OF DEPTH**

NO RE-ADJUSTMENT of depth is required when changing from one code card to another. The depth indicator marks on each code card are positioned for correct alignment when using the factory cutter wheels. No special washers are required on either side of the cutter.

The need to re-adjust the depth is rare and should be done only after the more common causes for mis-cut keys are eliminated.

Remember, when originating a key by code you do not have access to an operable key. Quite often code numbers are mis-read, locks are coded incorrectly when they are new and code books occasionally have typographical errors. Be aware of these unintentional errors that detract from the successful cutting of keys by code. After eliminating the above mentioned causes for mis-cut keys and checking for correct calibration - then proceed.



DEPTHS		SPACES		JAW: A	CUTTER: CW-14MC
#	INCH	MM	#	INCH	MM
0	.335	8.51	1	.231	5.87
1	.320	8.13	2	.387	9.83
2	.305	7.75	3	.543	13.79
3	.290	7.37	4	.699	17.75
4	.275	6.99	5	.855	21.72
5	.260	6.60	6	1.011	25.68
6	.245	6.22	7		
7	.230	5.84	8		
8	.215	5.46	9		
9	.200	5.08	10		
			11		
			12		

DEPTH INCREMENT		SPACE INCREMENT	
INCH	MM	INCH	MM
.015	.38	.156	3.96

.231-  
 .156 TYP.  
 123456  
 .015 TYP.

\*DSD#060 • SAFETY FACTOR=6 • PROG. STEP=2  
 \*BLANKS SHOULD HAVE PROPER BACKMILLED RADIUS

COPYRIGHT © 1995 HPC, INC.  
 SCHILLER PARK, IL USA  
 DESIGNED AND MANUFACTURED BY HPC  
 PRINTED IN USA

SCHLAGE LARGE PIN  
 CMB  
 C45

Cut a key by code and compare carefully measured depths against a code card.

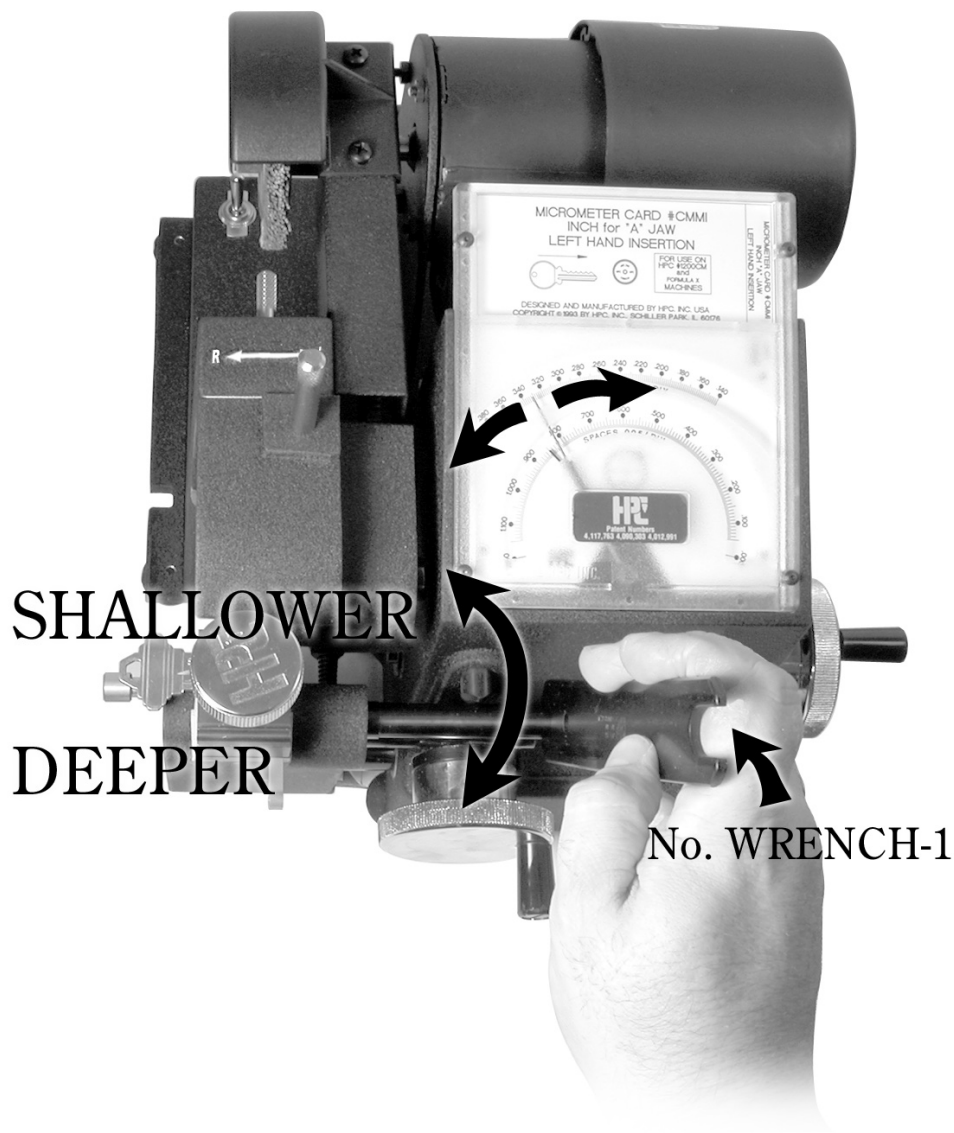

The two flats on the end of the eccentric shaft allow a 3/8" open end wrench (such as No. WRENCH-1) to rotate the eccentric shaft either towards you, making the depths deeper, or away, making the depths shallower. **There should be no need to loosen the two set screws.** The maximum range of the eccentric shaft is 90° when pulling towards you (a maximum of -.015" in depth change) and 90° when pushing away (a maximum of +.015" in depth change). Therefore only a small turn is used to change depths.

- Very rapid minor depth adjustments are made by comparing the depth of a cut against the code card and then rotating the eccentric shaft slightly as required.

# 8.0

# RE-CALIBRATION OF SPACE

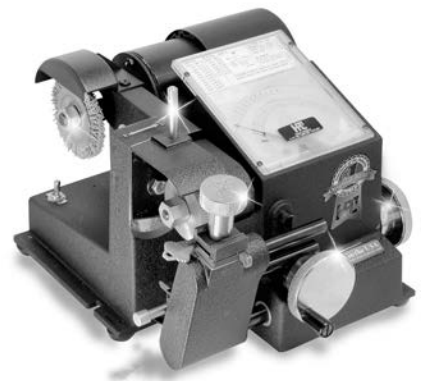

## **ATTENTION: PLEASE READ BEFORE PROCEEDING.**

### **RE-CALIBRATION OF SPACE**

NO RE-ADJUSTMENT of space is required when changing from one code card to another. The space indicator marks on each code card are positioned for correct lateral alignment when using the factory cutter wheels. No special spacing washers are required on either side of the cutter.

The need to re-adjust the space is rare and should be done only after the more common causes for mis-cut keys are eliminated.

Remember, when originating a key by code you do not have access to an operable key. Quite often code numbers are mis-read, locks are coded incorrectly when they are new and code books occasionally have typographical errors. Be aware of these unintentional errors that detract from the successful cutting of keys by code. After eliminating the above mentioned causes for mis-cut keys and checking for correct depth calibration - then proceed.

If re-adjustment of space is needed, follow the instructions for tip-gauged space adjustments first. Then proceed with shoulder-gauged space adjustments. Because the tip gauges are built into the bottom jaw and the shoulder gauge is mounted on its own pivot, re-adjusting the shoulder gauge may not properly re-calibrate your 1200CMB.



**CUTTING TOO CLOSE OR TOO FAR FROM  
THE TIP ON KEYS GAUGED FROM THE TIP.**



Select an original large cylinder type tip-gauged cut key such as Best or Falcon.

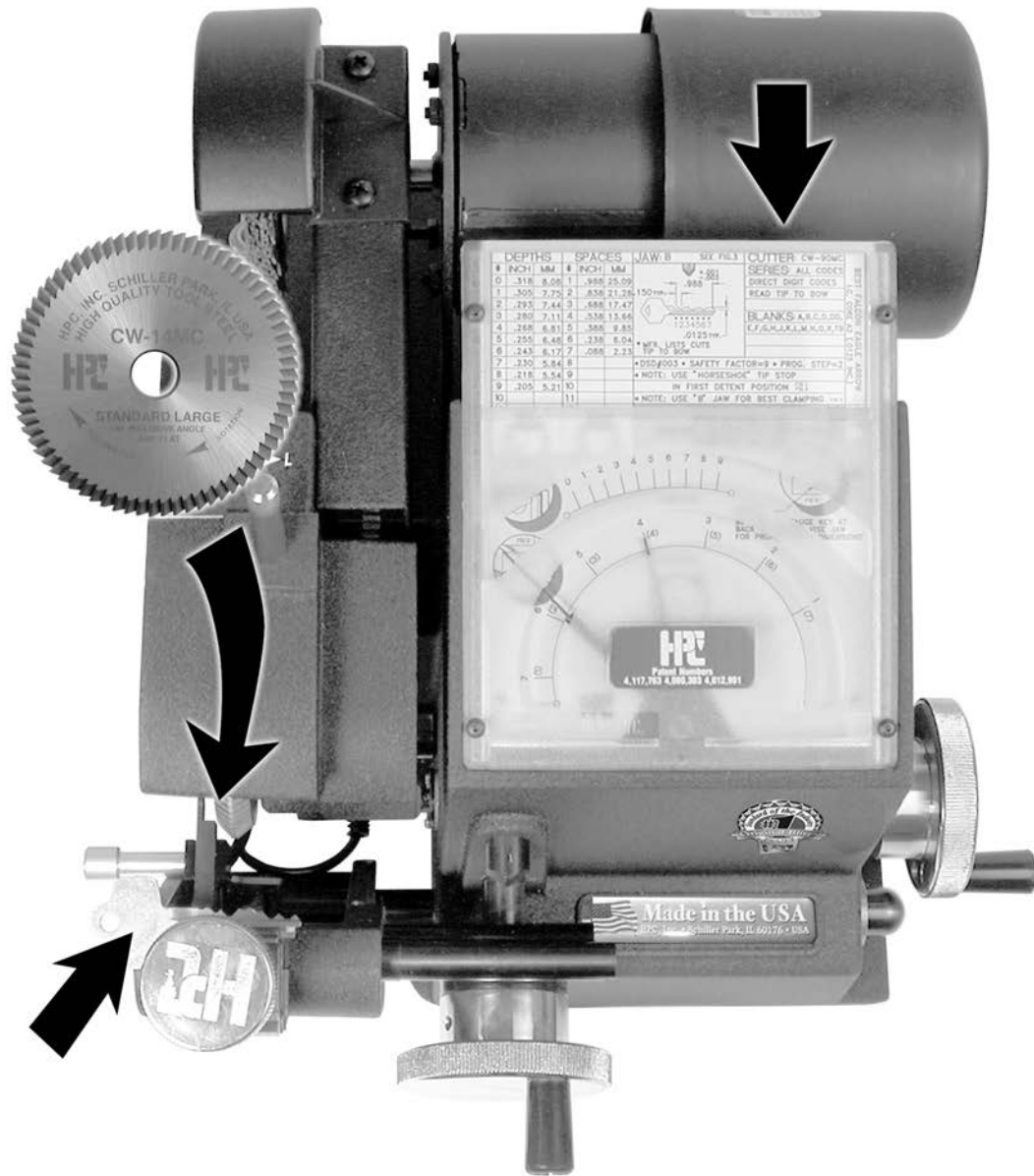

Put on the correct cutter and insert the correct card. Then, gauge and clamp the key.

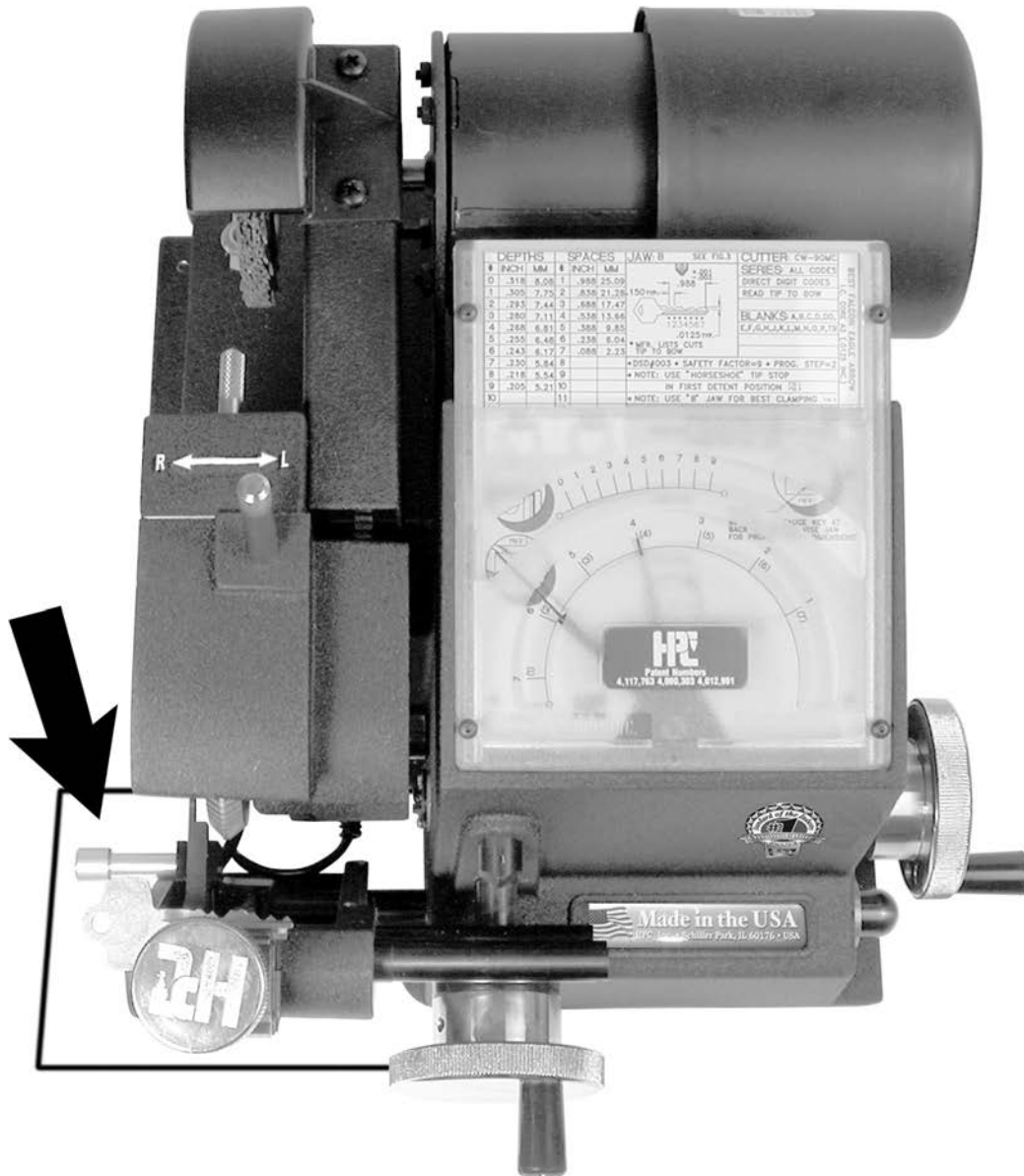

Place a white piece of paper beneath the cutter for improved vision of alignment.

**NOTE: Unplug machine for these and the following operations.**

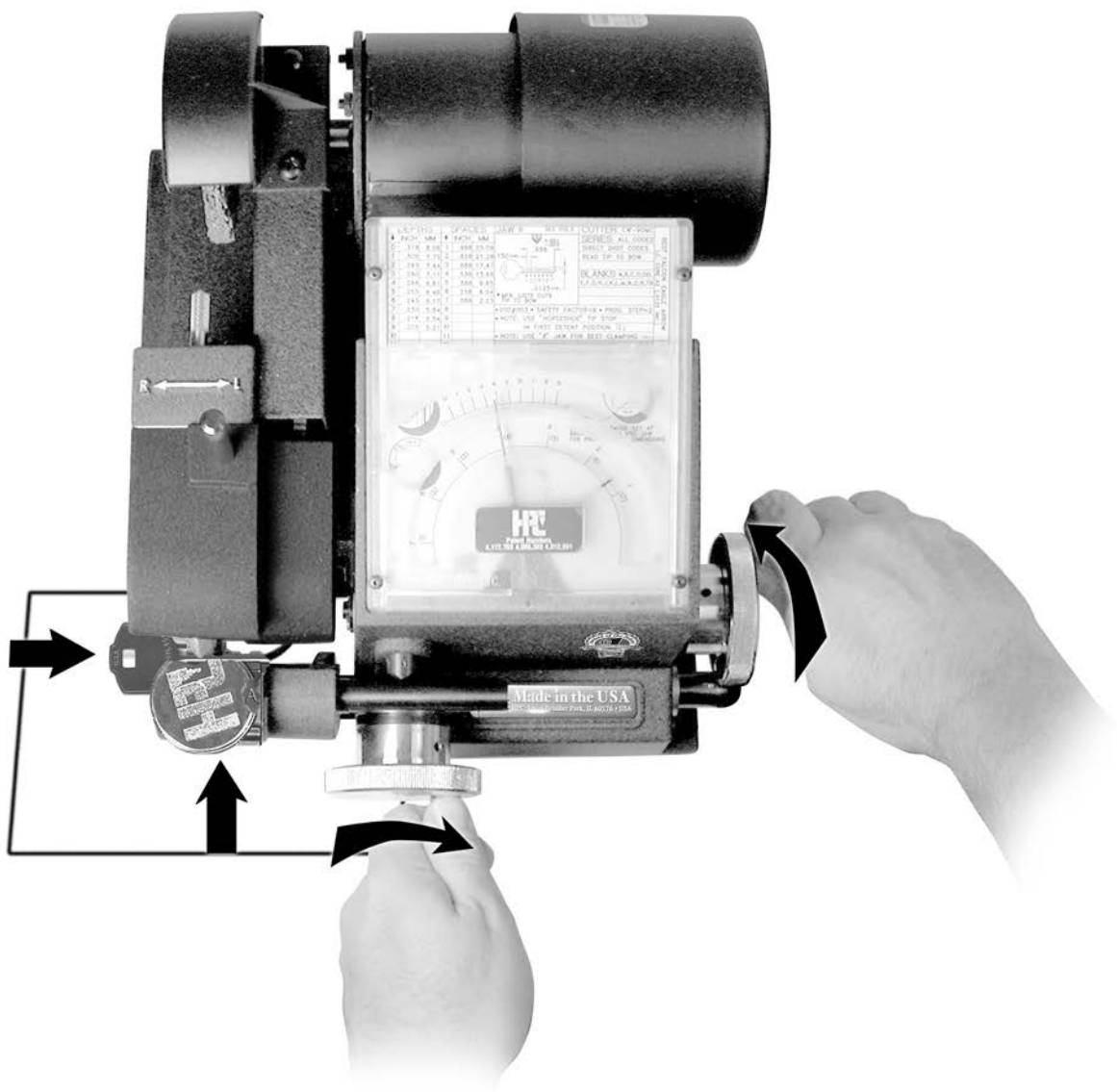

Rotate lateral crank to position the key with the most easily seen cut carefully centered beneath the cutter as shown. Rotate the depth crank until the cutter is fairly deep within the cut, (Deepest cuts are usually the easiest to see.)

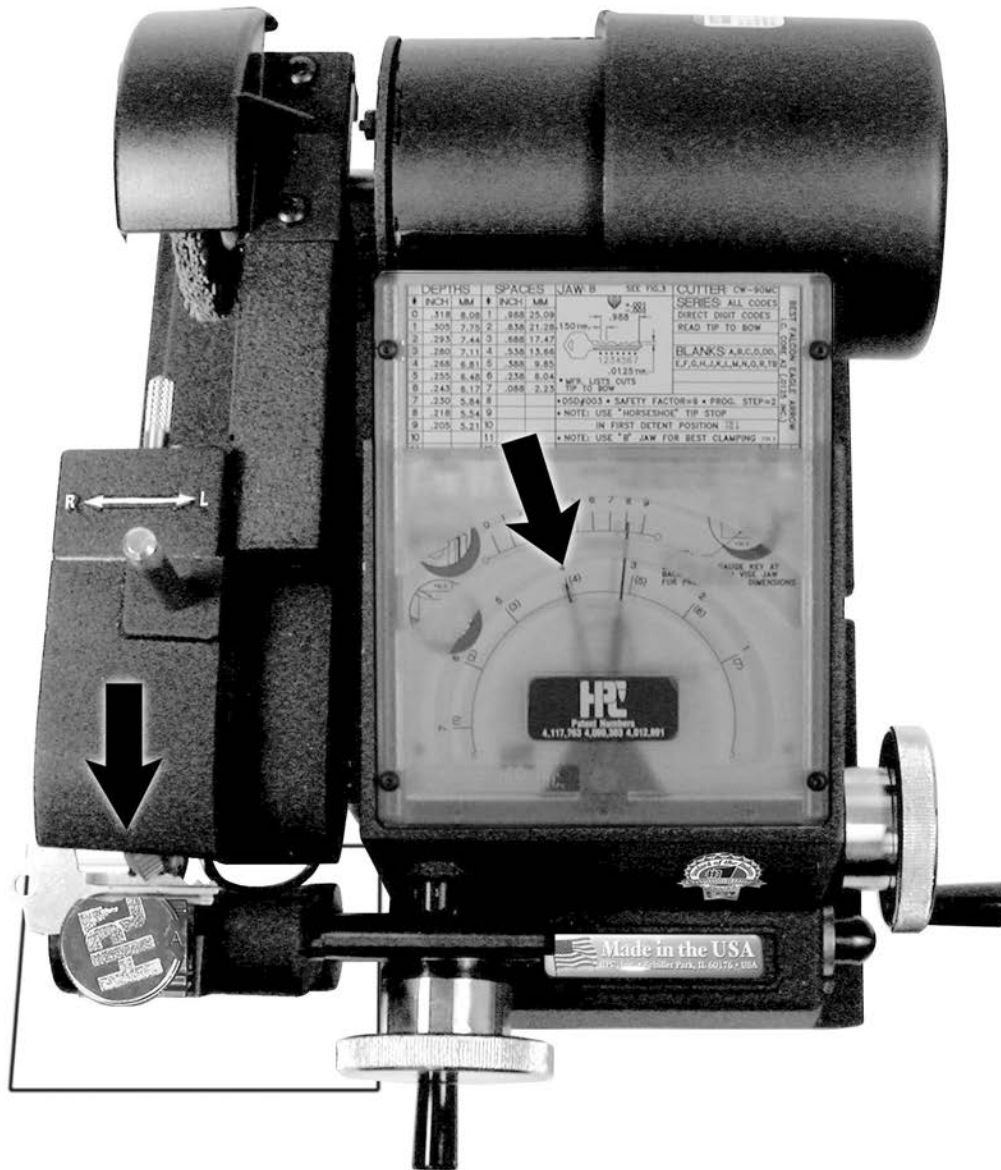

If space indicator needle is centered over the corresponding space mark, the tip stop space adjustment is correct.  
Go no further.

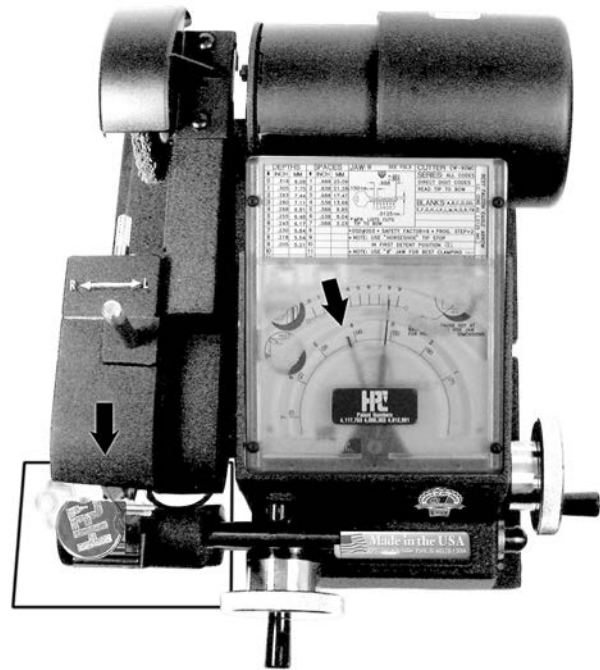
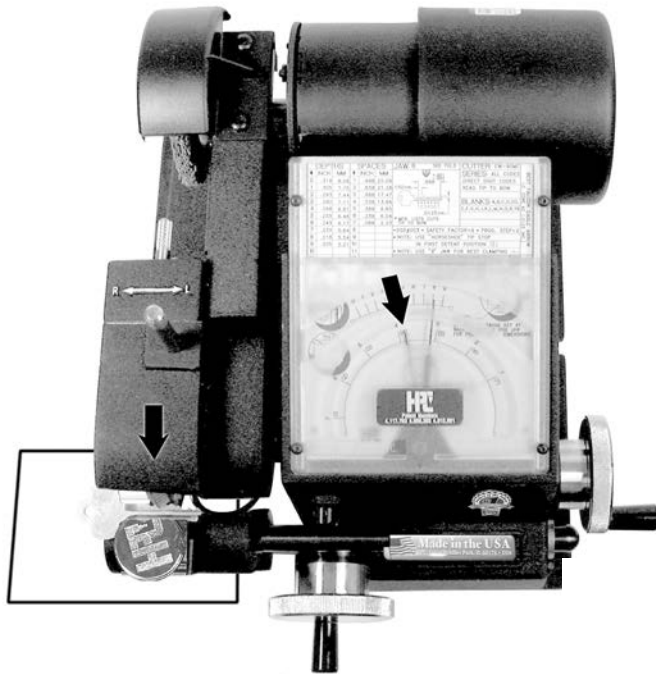

If the space indicator needle is offset to the right, the machine is cutting too close to the tip.

If the space indicator is offset to left, the machine is cutting to far from tip.

(Note: Re-calibration of tip **does necessitate** re-calibration of shoulder space. See next section.)

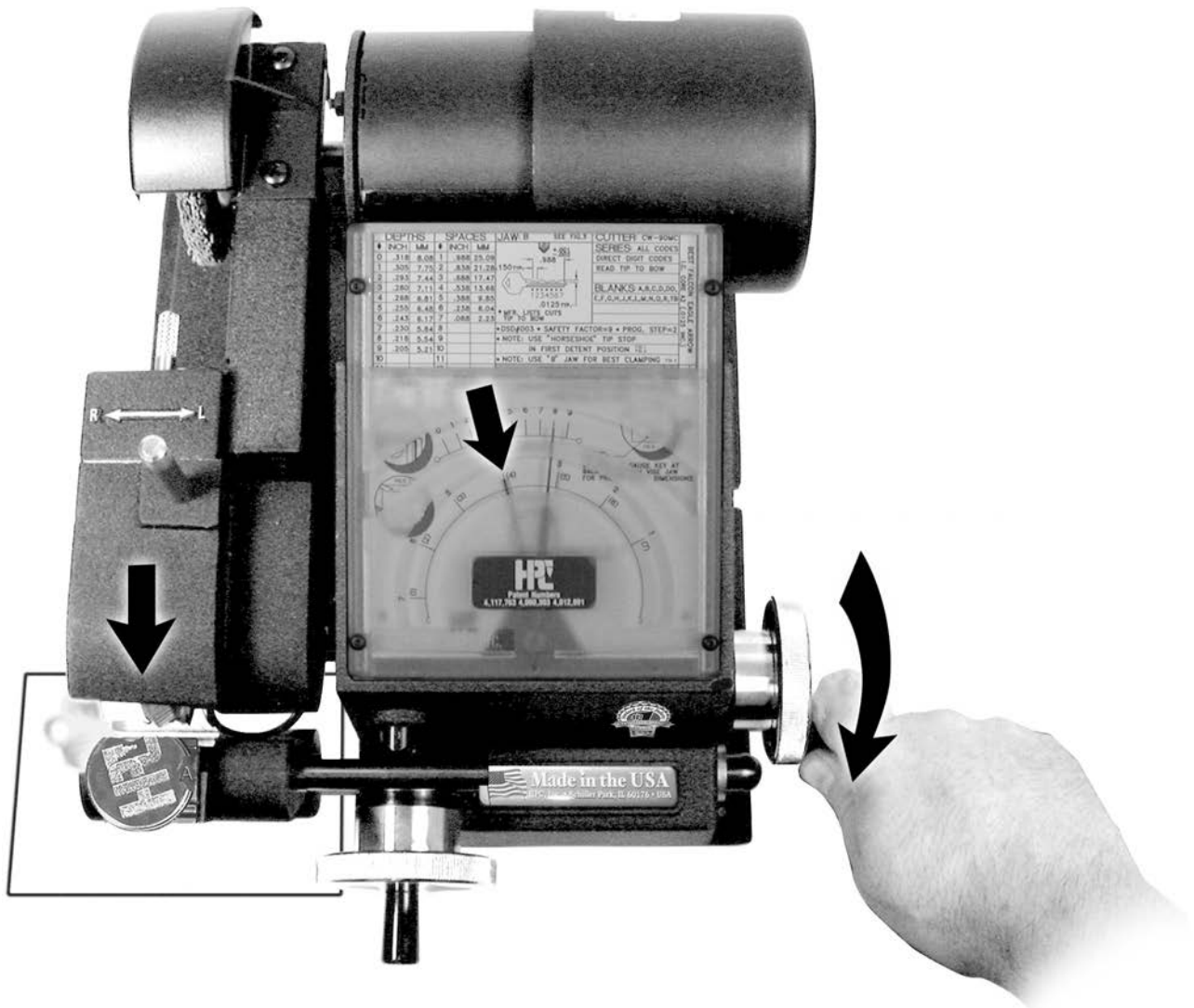

Rotate the lateral crank until the indicator needle is centered over the corresponding space mark as shown. Rotate the Depth crank until the cutter is fairly deep within the cut.

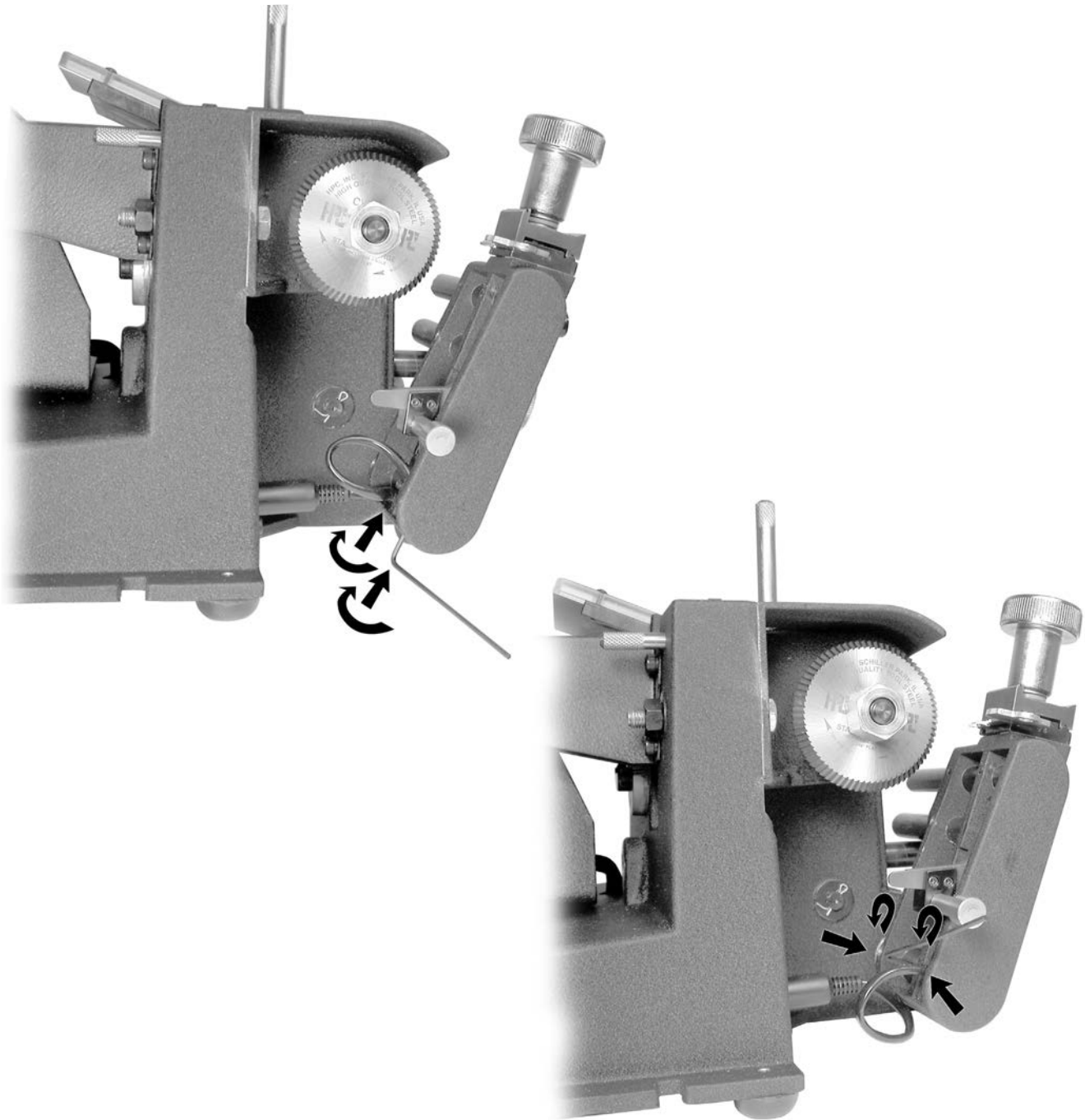

Loosen the four set screws that hold the pivot arm onto the pivot arm shaft. DO NOT REMOVE PIVOT ARM.



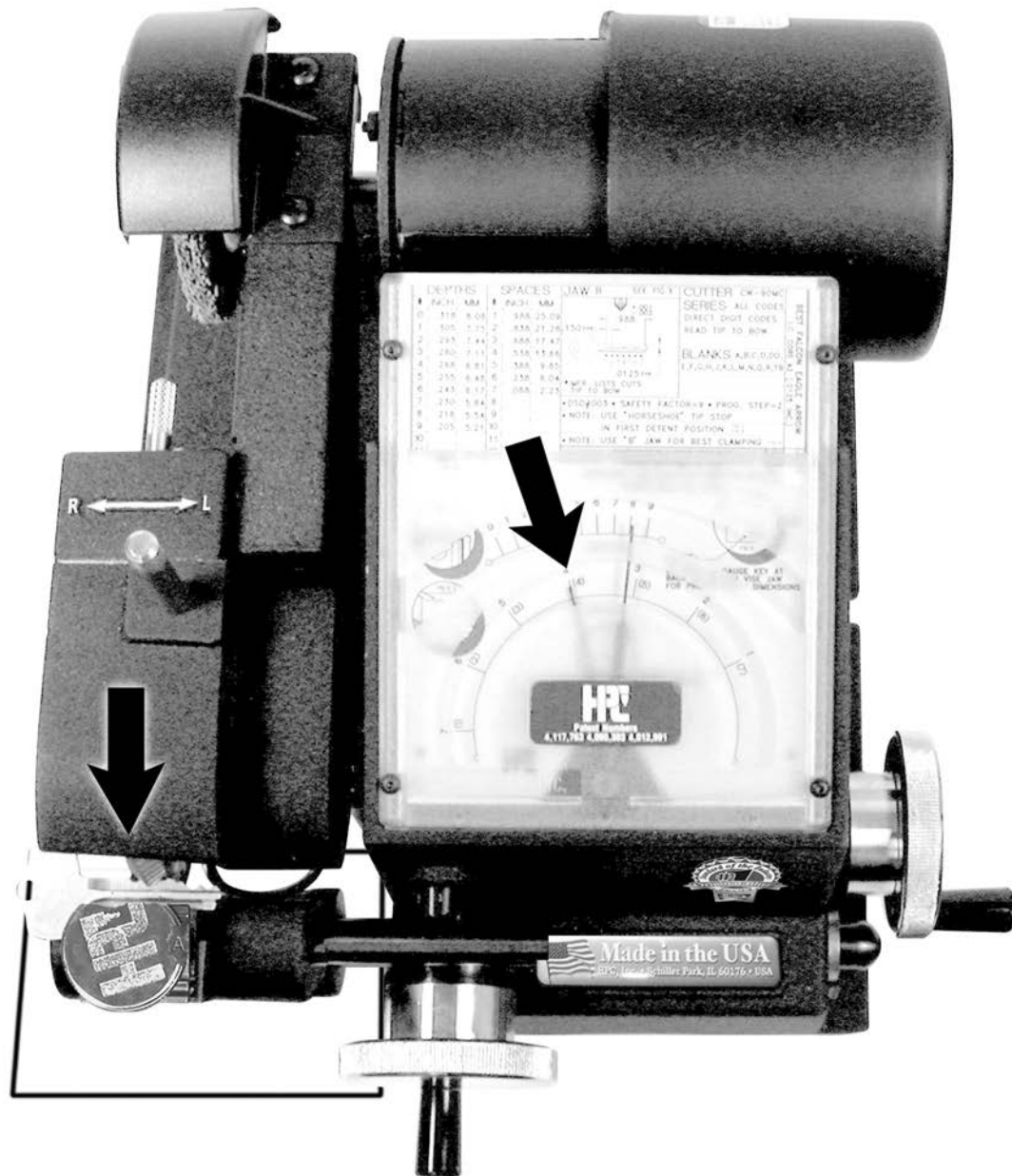

Re-position the space indicator needle if it has moved while loosening the set screws.

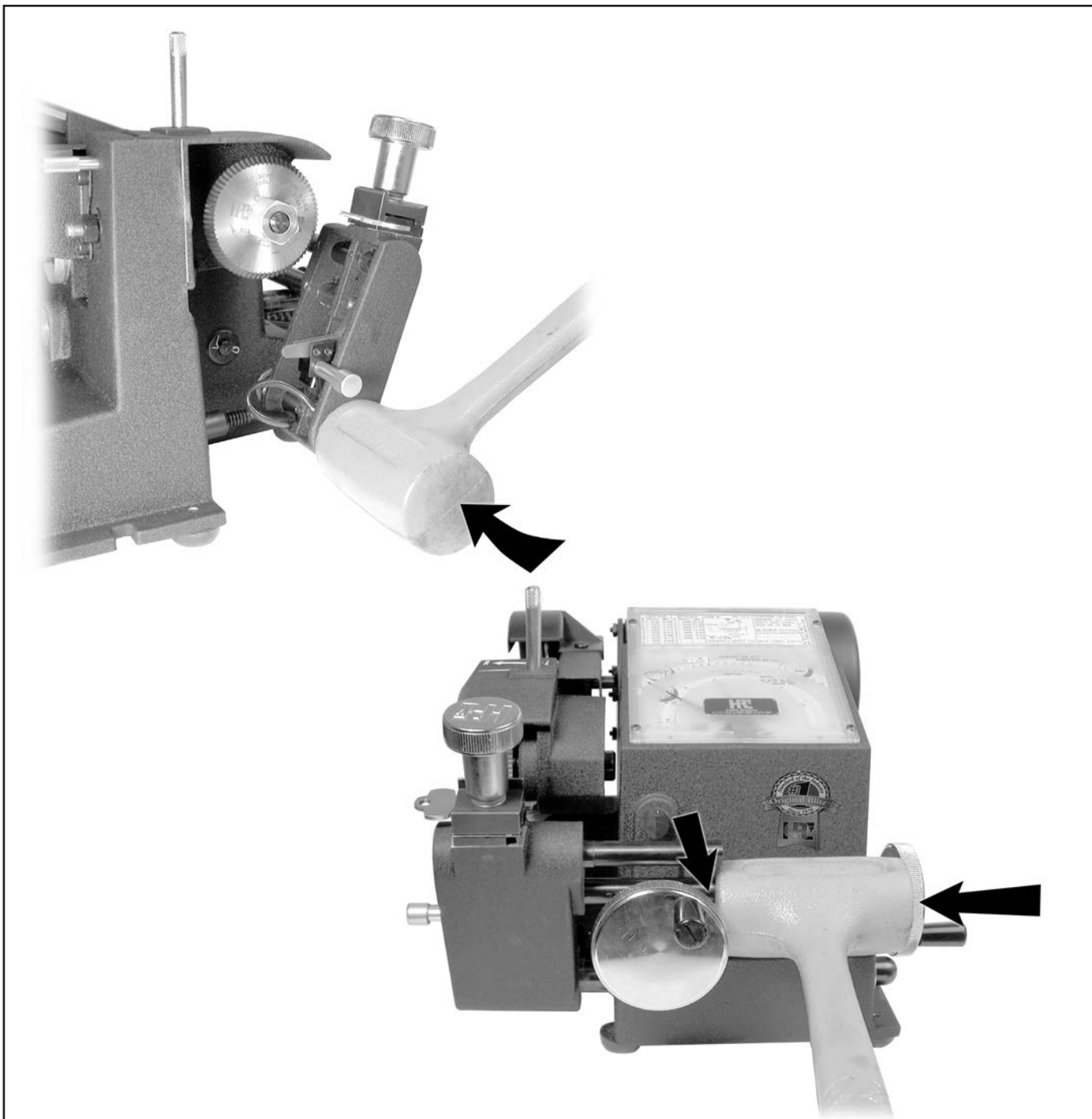

With a small rawhide or plastic mallet, “lightly” tap the lower left side of the pivot arm until the pin seat of the cut is directly opposite the flat of the cutter, as shown previously. (Be sure all FOUR set screws are loose.)

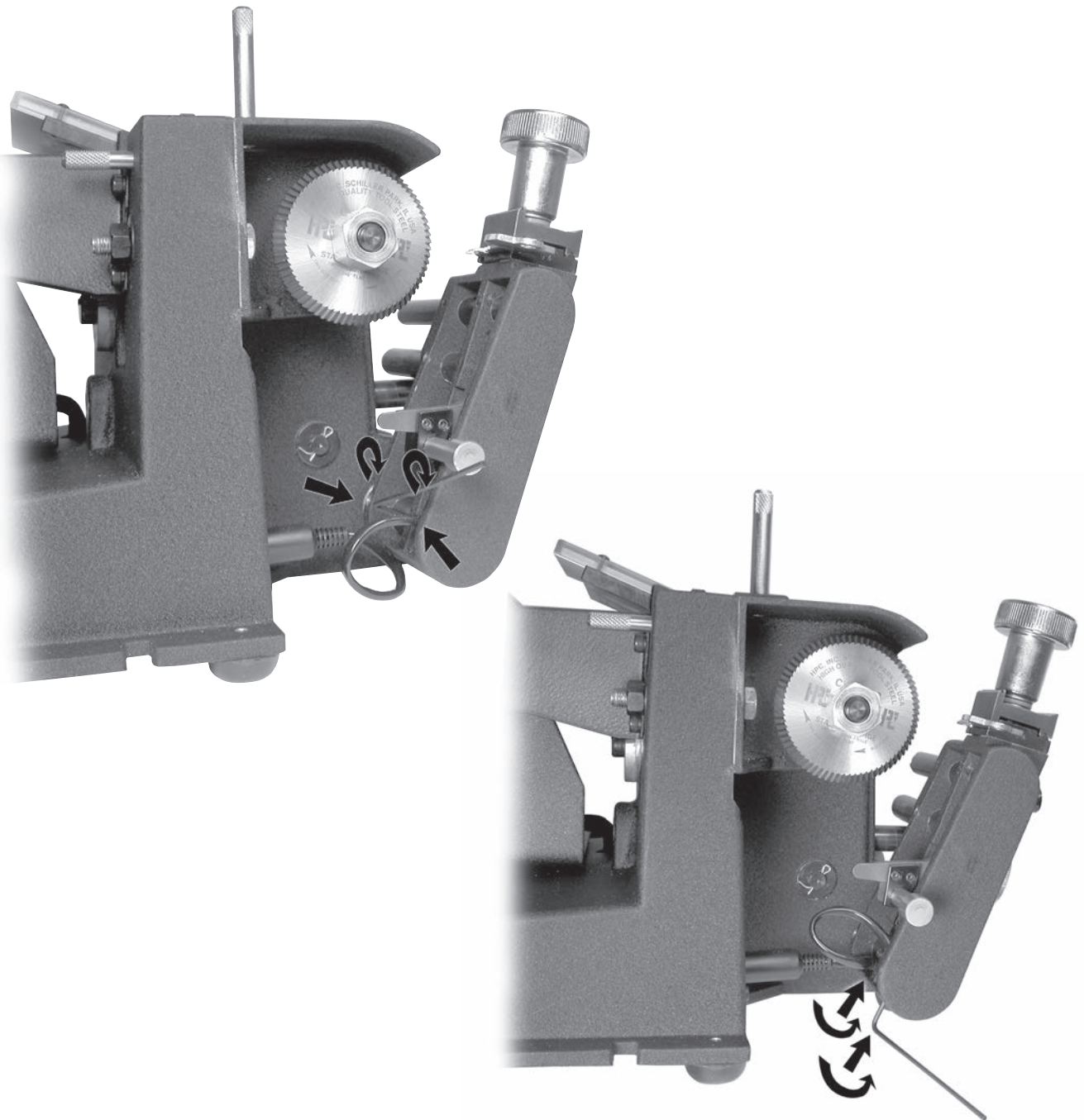

With the cutter aligned opposite the cut and the space indicator needle centered over the corresponding space mark, tilt the machine up, if necessary, (without disturbing the setting) and re-tighten the set screws.

**CUTTING TOO CLOSE OR TOO FAR FROM THE  
SHOULDER ON KEYS GAUGED FROM THE SHOULDER.**



Select an original large cylinder type shoulder-gauged cut key, such as Schlage.

\*Always check spacing on a tip stop key first, before adjusting for shoulder-gauged keys.

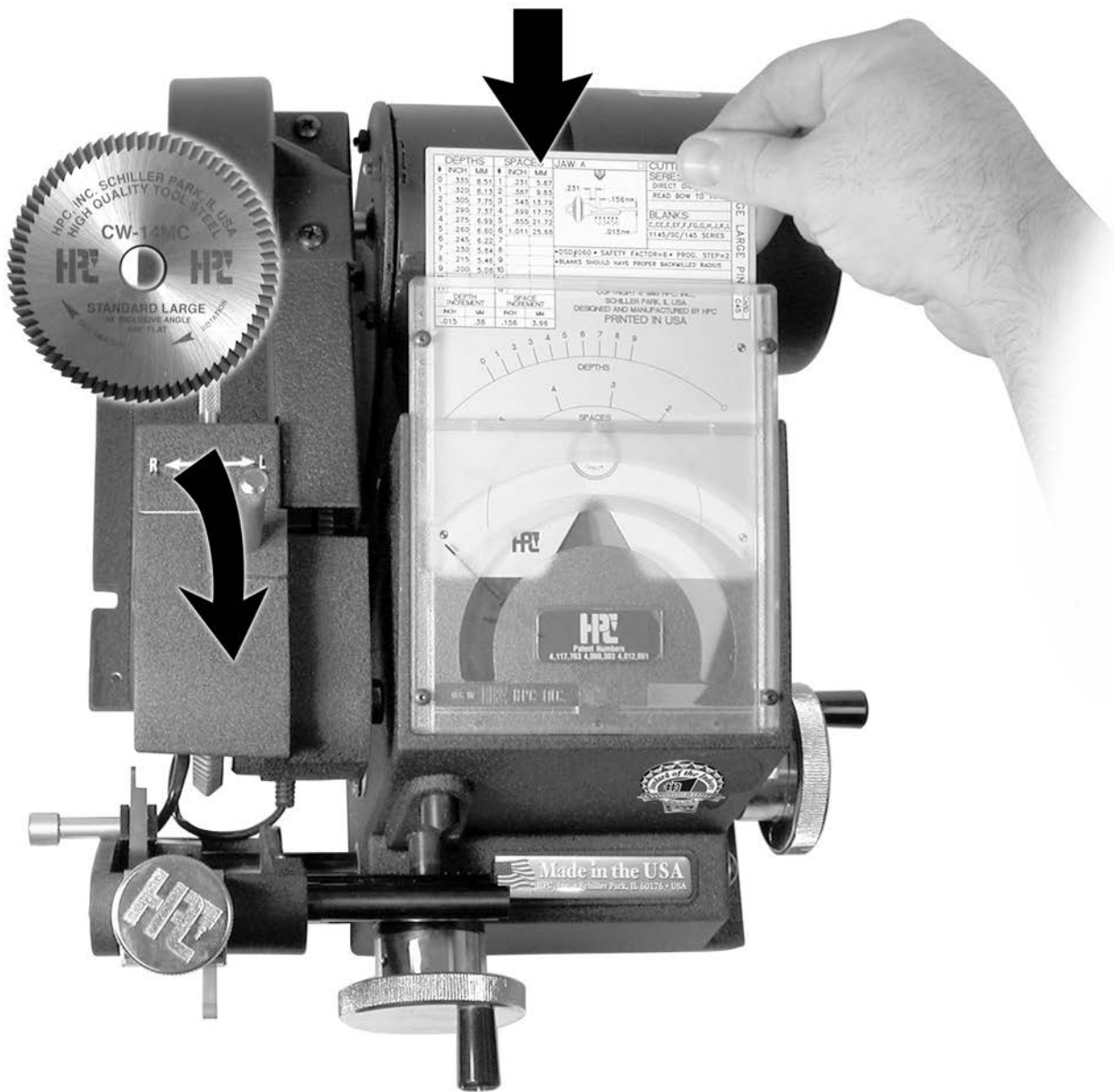

Insert the correct Code Card. Put on the correct cutter.

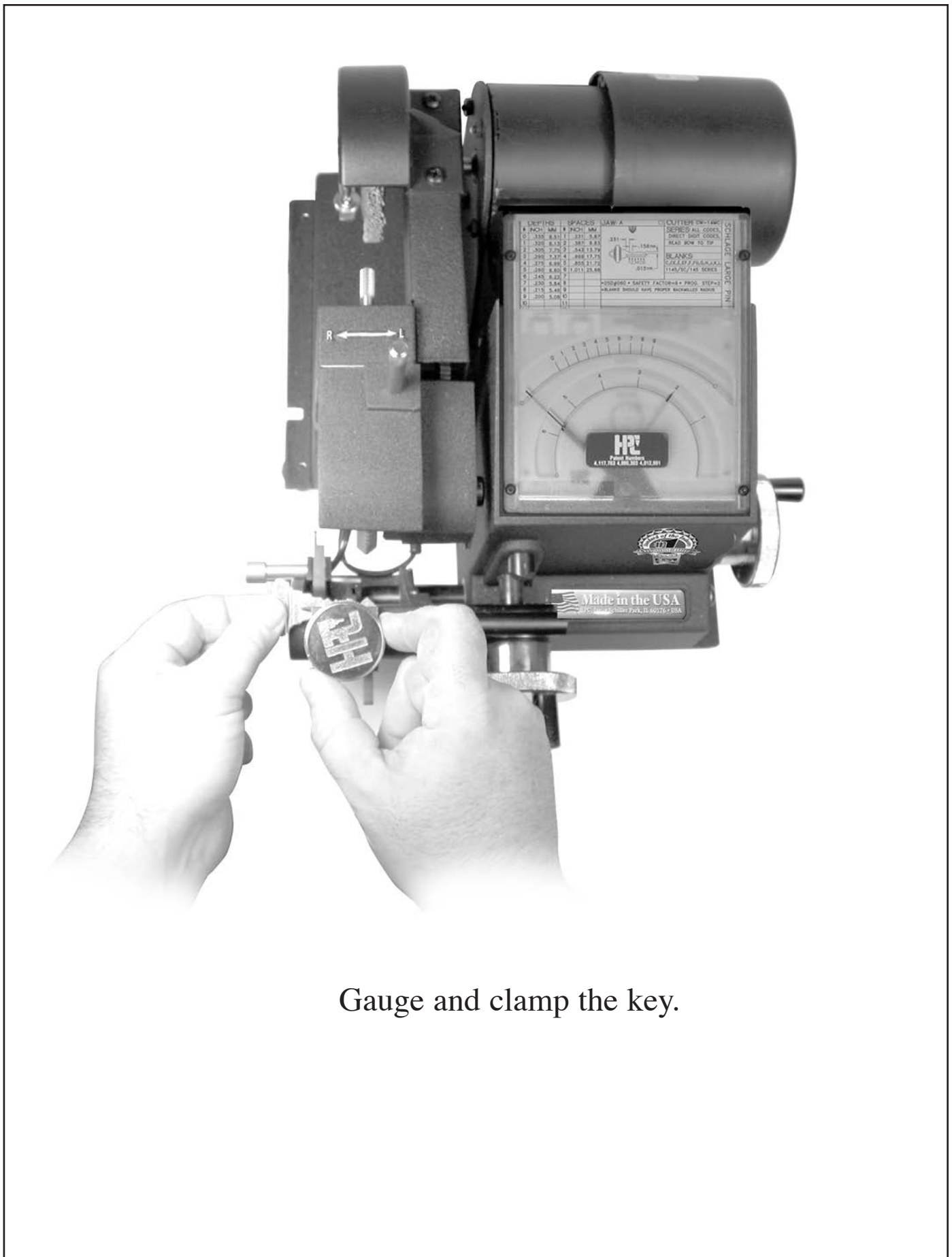

Gauge and clamp the key.

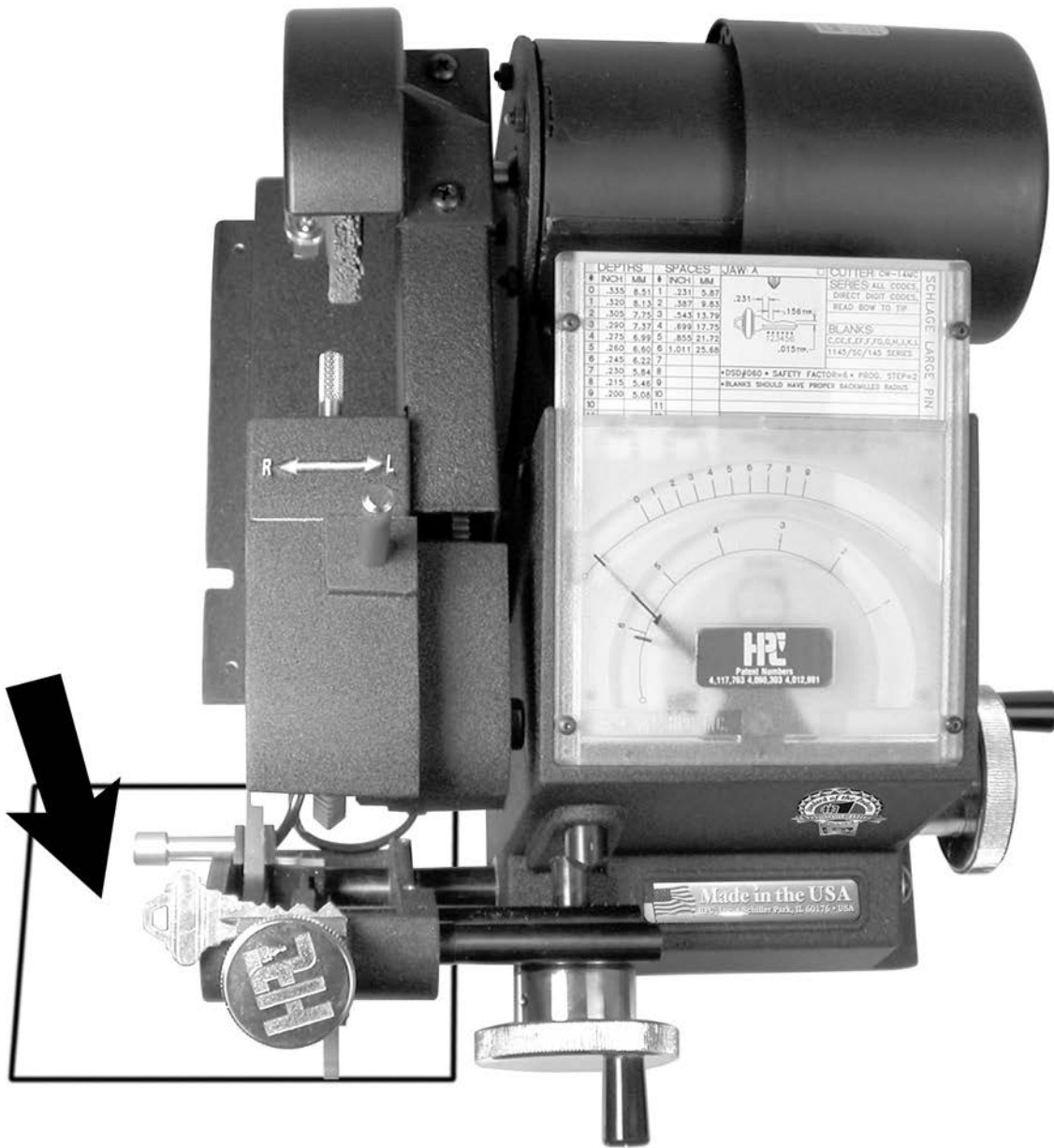

Place a white piece of paper beneath the cutter for improved vision alignment.

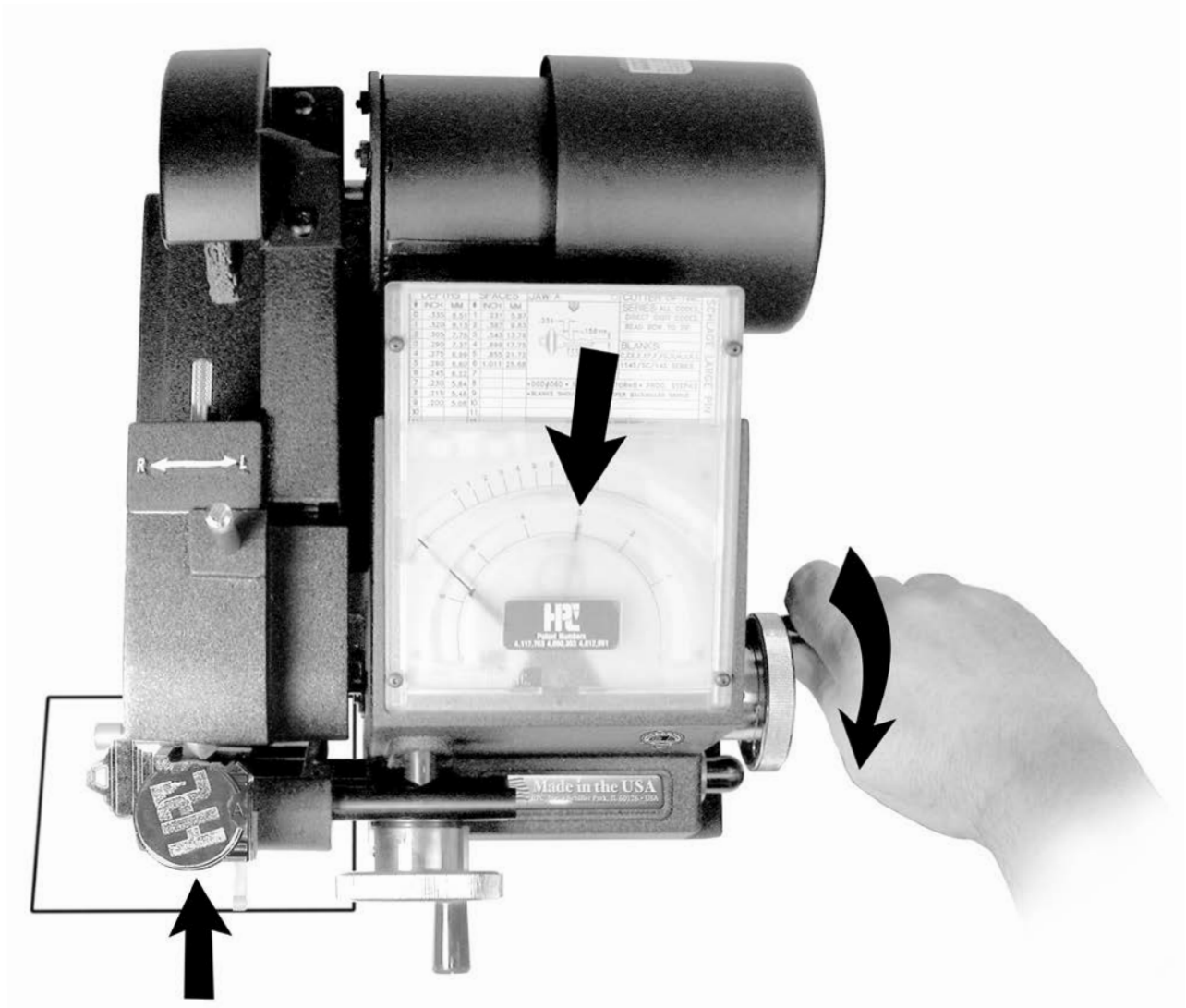

Rotate lateral crank to position the key with the most easily seen cut carefully centered beneath the cutter as shown. Rotate the depth crank until the cutter is fairly deep within the cut. If space indicator needle is centered over the corresponding space mark the space adjustment is correct. Go no further.



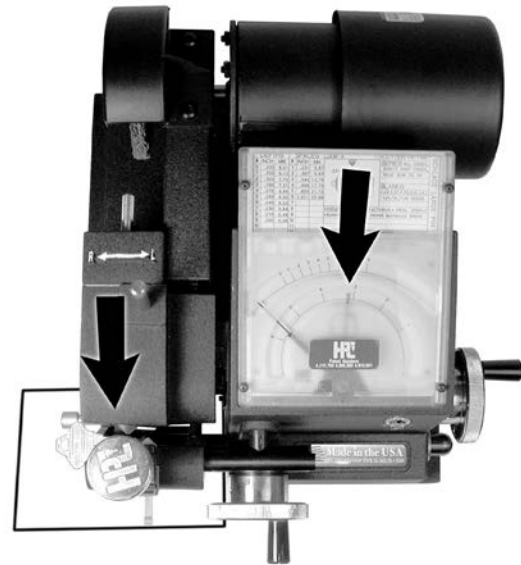
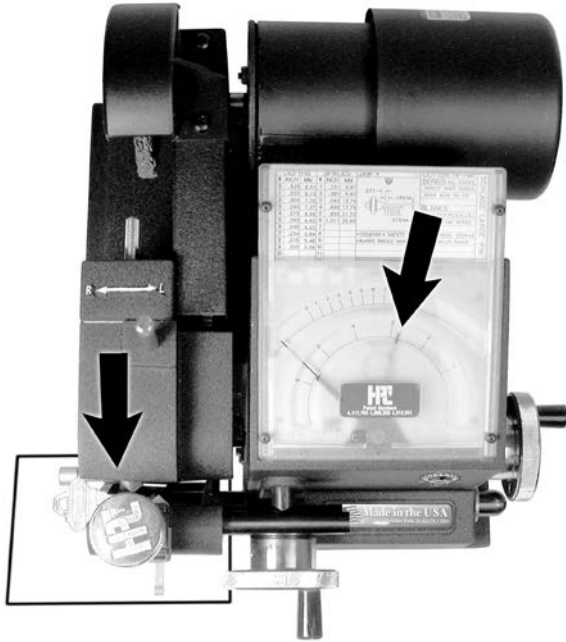

If the space indicator needle is offset to the right, the machine is cutting too far from the shoulder.

If the space indicator needle is offset to left, the machine is cutting too close to the shoulder.

(Note: Recalibration of shoulder spacing **does not necessitate** recalibration of tip space.)

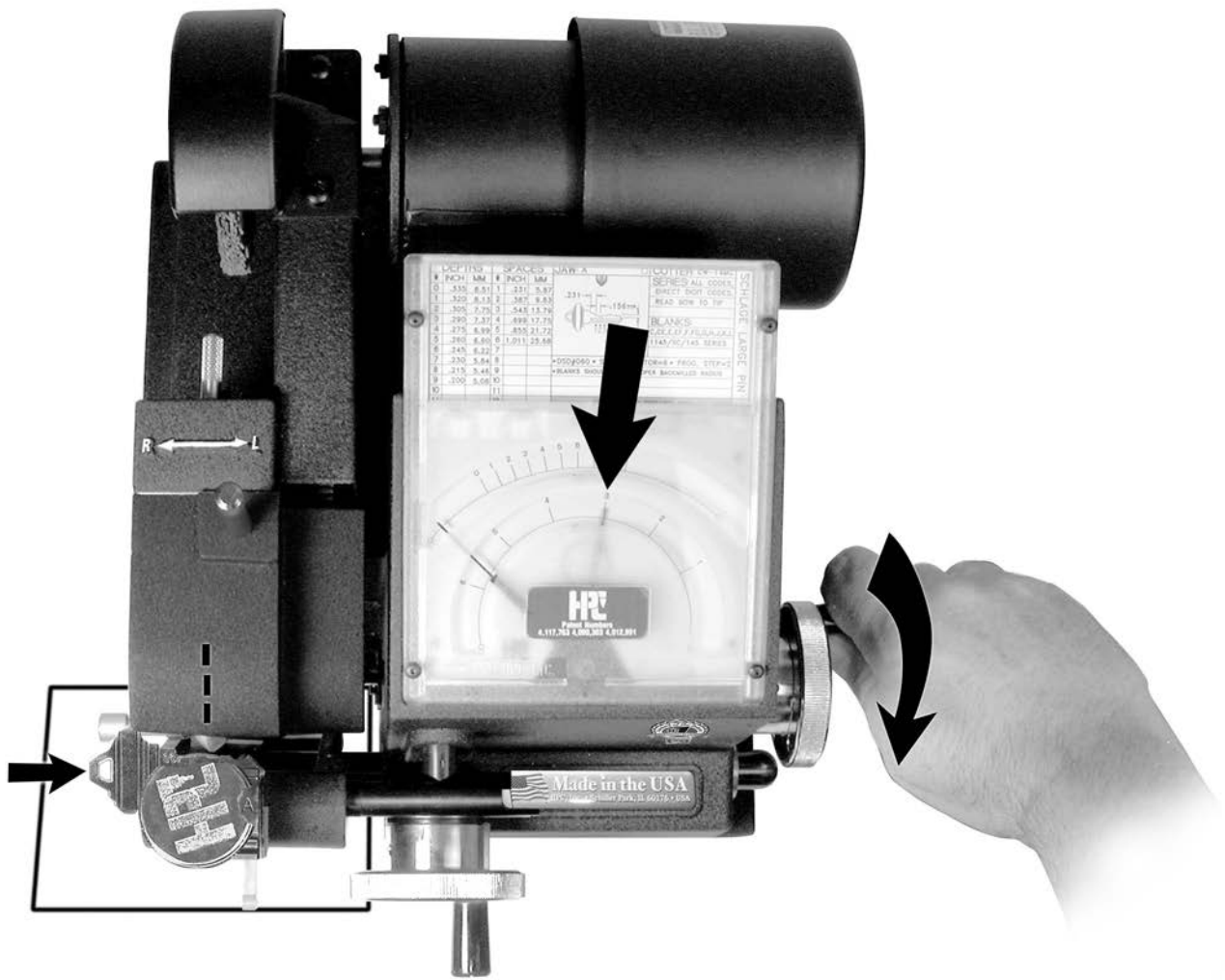

**NOTE: Unplug the machine for these and the following operations.**

Rotate the lateral crank towards you until the space indicator needle is centered over the corresponding space mark as shown.

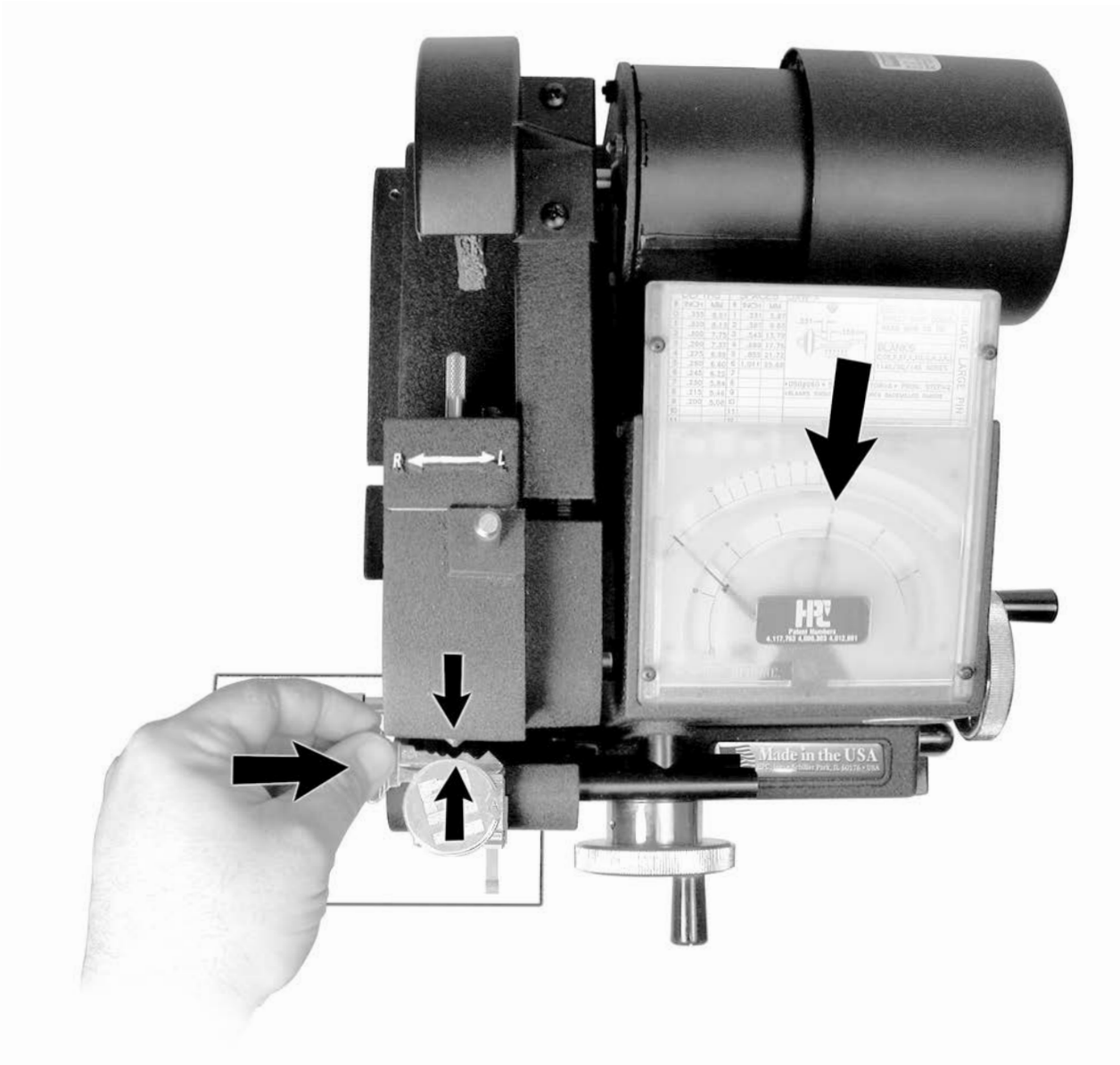

Loosen the key on the vise. Slide the key until the pin seat of the cut is directly opposite the flat of the cutter as shown. Tighten the key on the vise.

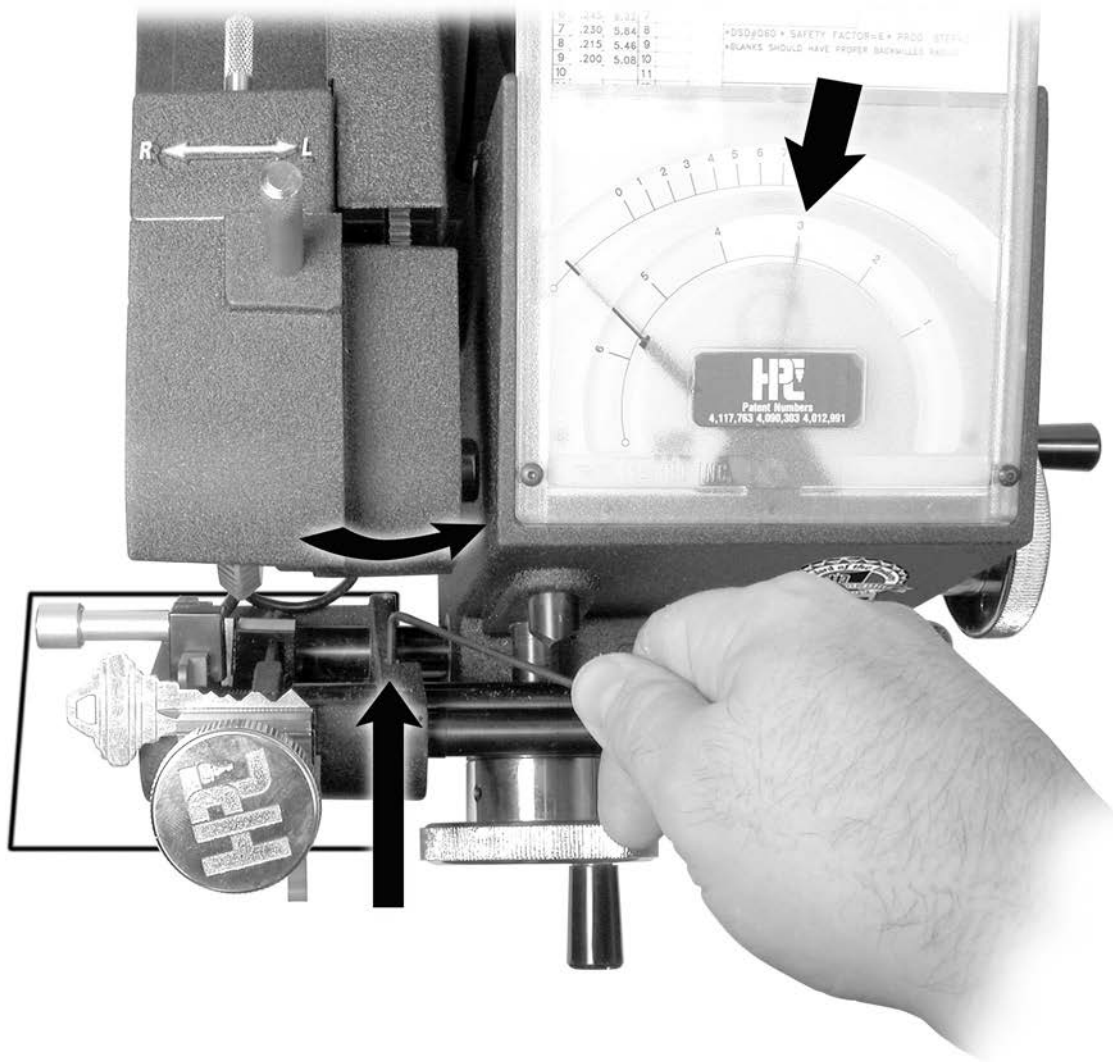

Loosen the set screw that holds the shoulder gauge turn bar onto the pivot arm (CM-1024X).

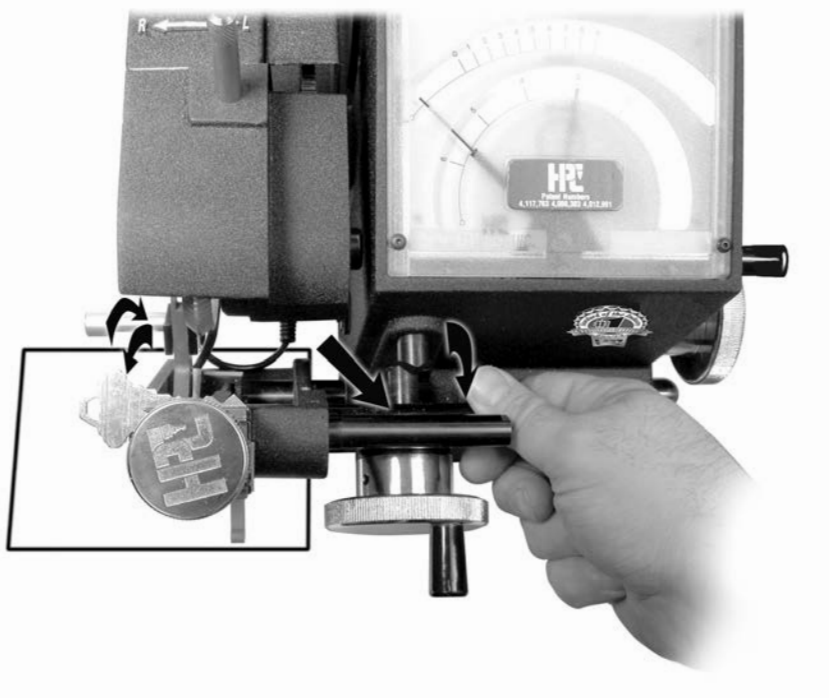
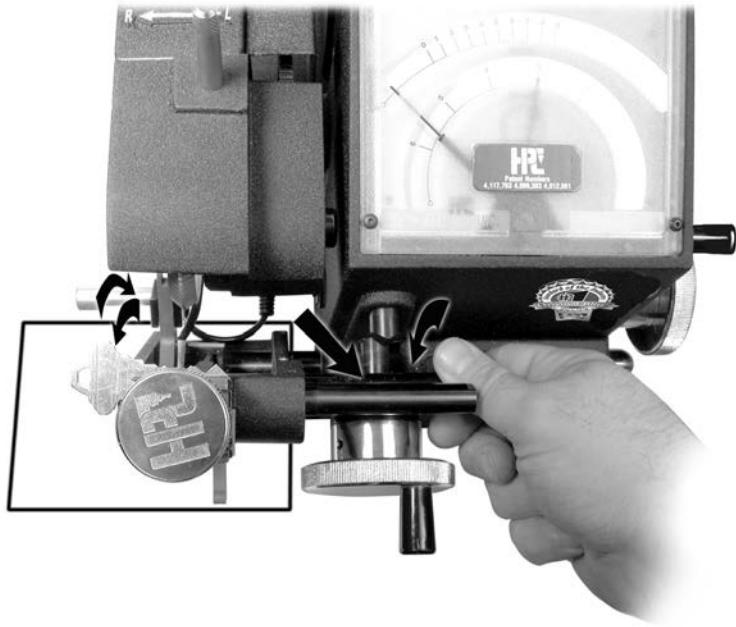

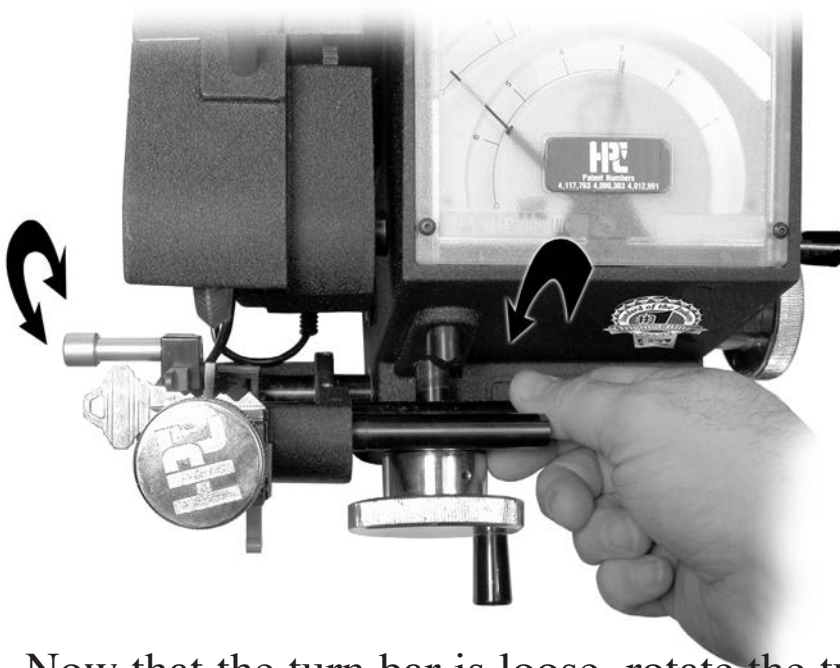

Now that the turn bar is loose, rotate the turn bar clockwise or counter-clockwise to move the shoulder gauge toward the shoulder of the key. The left side of the gauge should end up just barely touching the shoulder of the key as shown (as in normal gauging). Do not use pliers or any tool that will scratch or mar the surface of the turn bar.

Tighten the set screw that holds the turn bar onto the pivot arm.

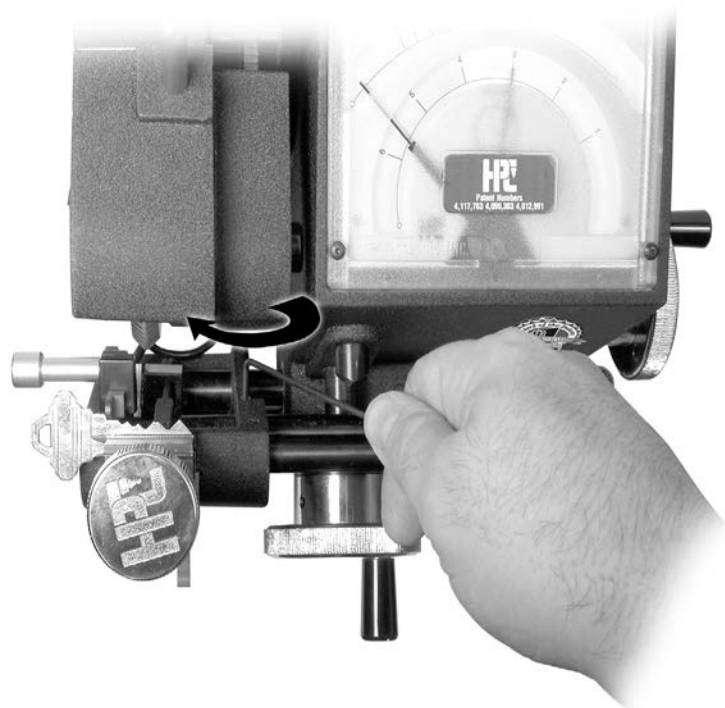

# 9.0

## PREVENTIVE MAINTENANCE, LUBRICATION, REPAIRS AND GUARANTEE

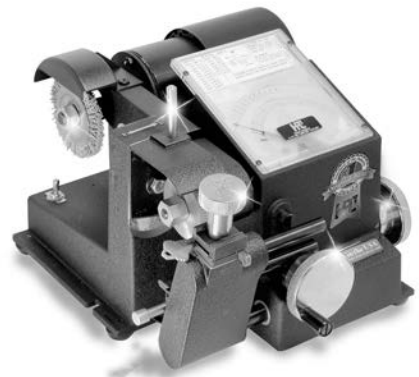

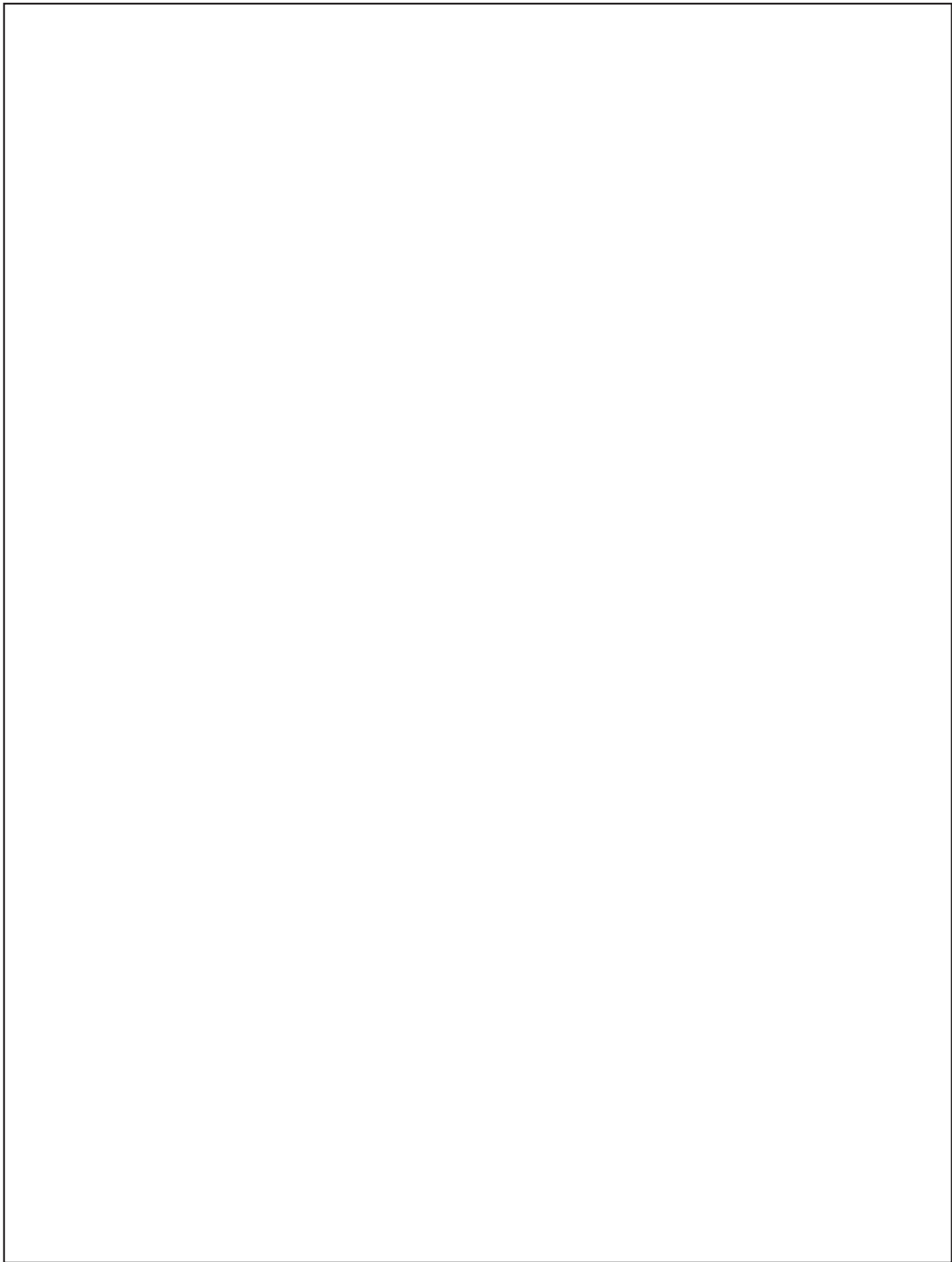



# LUBRICATION PREVENTIVE MAINTENANCE, REPAIRS and WARRANTY

1. **WARRANTY** - The Blitz™ Code Machine is fully warranted for one year from the date of purchase, against factory defects in material and workmanship. Mail the Warranty Card and a copy of your invoice to us immediately, to validate your warranty. Should your machine require factory repairs, please contact the HPC Service Center before sending in the machine.  
During the one year warranty period, you will be billed for handling and shipping only.
2. **MOTOR** - The motor is equipped with sealed bearings that require no lubrication.
3. **CUTTER HEAD** - The cutter head is equipped with precision ball bearings for years of trouble free service and requires no lubrication. The cutter head swivel surface and plunger angle holes should be given a light coat of LPS#3 or equivalent, once every 4 to 6 months.
4. **DEPTH FEED CRANK BEARING** - The black Delrin bearing (No. CM-1045) should be cleaned and a light coat of heavy grease applied when required, in order to maintain it's smooth feel.
5. **BEARINGS AND SLIDING SURFACES** - These are to be given a light coat of a light grease at least every six months.
6. **EXPOSED STEEL SURFACES** - All remaining exposed steel shafts, cutter, etc., should be sprayed with WD-40 or equivalent light oil at least every 6 months. Wipe off any excess.
7. **CLEANING** - Remove all brass chips, dirt and grit from the surface of your machine daily, with a soft bristle brush. Take particular care in keeping the key vise jaw area clean and free of all residue build-up.
8. **CODE CARDS** - The Code Cards are made of credit card stock and die cut to extremely close tolerances. Dirt is easily washed off with a mild non-abrasive liquid detergent, such as dishwashing soap and lukewarm water. Dab lightly with a soft cloth until dry. Never use an abrasive or solvent-based cleaner to wash these Code Cards!
9. **CALIBRATING DEPTH FOR RE-SHARPENED CUTTERS** - As cutters become worn, the alternative to purchasing a new set, would be to sharpen them. (HPC does not sharpen cutters.) In order to maintain matched cutter diameters, all cutters for this machine must be sharpened at the same time, and all diameters must be sharpened proportionately. The diameter of a resharpened cutter is, smaller and therefore will make cuts shallower-if no depth adjustment is made. This is easily accomplished by rotating the eccentric shaft with a 3/8" open end wrench.  
\*See depth adjustment section (Section 6.0) for full explanation of the eccentric shaft adjusting process.
10. **DRIVE BELT** - The drive belt (No. CM-1083MA) was selected especially for this machine and should give years of good service. If it becomes worn or broken and requires replacement, be sure to install the new belt with the teeth outward. Note: The drive belt is somewhat more noisy when it is made to "cross-over" as the cutter head is swiveled to either the left or right angle when cutting  
\*Medeco® keys.

\*Medeco® is a registered trademark of Medeco Security Locks, Inc.



Blitz™  
No. 1200CMB



# HPC SERVICE CENTER

If your HPC Key Machine should require service, please note the following information:

**HOURS:** The HPC Service Center answers questions involving key machine repair and replacement parts Monday through Friday from **8:00 am to 3:30 pm**

Please call **800-323-3295** (HPC) or **800-434-8960** (Hudson Lock Company).

**REPAIRS:** We recommend the replacement of cutters, brushes and external parts, the preventive maintenance and recalibration (as outlined in this manual) be the only repairs or adjustments that are done by the user. Internal parts and mechanisms should be factory-repaired only. Additional repair charges may be incurred by attempting to make these types of repairs by yourself.

**FACTORY SERVICE:** If you need to send your HPC key machine in for repair, first call the HPC Service Center to obtain a Repair Order number, then follow these instructions:

Include a letter explaining the problem you are having, as well as any other work you want done on the machine. Make sure your business name, address and phone number, as well as the name of the contact person are on the letter.

Your machine should be equipped with an HPC cutter when it is sent in for repairs. If you are sending in a Blitz™ or CodeMax™ machine also include the Black Horseshoe Tip Stop to insure proper tip gauge calibration. Please do not send in any other accessories (such as other cutters and code cards).

Pack the machine securely in a box strong enough to prevent damage during shipping (preferably the original box).

The Repair Order Number should be marked on the outside of the box.

All machines must be shipped prepaid. Collect shipments will not be accepted.

**REPAIR CHARGES & ESTIMATES:** Upon receipt and evaluation of your machine our technicians will provide a written estimate (by fax) of the repair charges. Some problems may be detected only while the repair work is being done. If after informing you of the repair estimate it becomes apparent that the cost will be higher, you will be notified of the additional charges before any additional work is done.

**REPLACEMENT PARTS:** Key machine parts can be purchased through an Authorized HPC Distributor or directly from the HPC Service Center. When ordering parts over the phone, please have the part numbers and descriptions ready to expedite the ordering process. A parts listing and an exploded view drawing is included in this manual. If the parts are needed urgently, express processing is available at an additional charge.

**PAYMENT:** Payment for parts and repair is required at the time of repair and before the parts are shipped. We accept payment by credit card (Visa, Mastercard or Discover) or by check. Repaired machines and parts can also be sent C.O.D. with an extra charge. If you wish to have your Authorized HPC Distributor billed for the parts or repairs, the distributor must call us with approval of the billing and provide a purchase order number for the parts or work being done, before the machine is repaired or parts are shipped.

Unless otherwise specified, key machines that are not under warranty will be shipped C.O.D. with an extra charge after the repairs have been made.

**LOANER MACHINES:** Sorry, but we do not have loaner machines available.

Hudson Lock, LLC  
81 Apsley Street  
Hudson, MA 01749



1-800-434-8960  
1-800-323-3295  
fax: 978.562.9859  
sales@hudsonlock.com

# 10.0

## EXPLODED VIEWS & PART LISTINGS

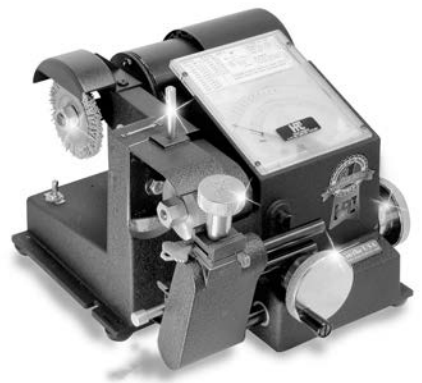

# 1200CMB PARTS LISTING

<b>#</b>	<b>Description</b>	<b>Stock #</b>	<b>#</b>	<b>Description</b>	<b>Stock #</b>
1.	Pivot Arm Complete	CM-1024X	24.	Retaining Ring	CM-50112
2.	Cutter Nut	CM-1039MA	25.	Screw	CM-50134
3.	Cutter	Sold Separately	26.	Lateral Crank Complete	CM-1044X
4.	Cutter Head Assembly	CM-1053X	27.	Lateral Rack Bracket	CM-1030
5.	Spring	CM-1079	28.	Pivot Arm Shaft	CM-1034
6.	Washer	CM-50100	29.	Rubber Foot	CM-50133MA
7.	Pivot Pin	CM-1043	30.	Dogging Screw	CM-1016
8.	Hex Nut	CM-50157	31.	Teflon Washer	CM-1086
9.	Belt	CM-1083MA	32.	Washer	CM-50100
10.	Cap Screw	CM-50158	33.	Spring	CM-1098
11.	Angle Index Pin	CM-1042	34.	Retaining Ring	CM-50126
12.	Hex Nut	CM-50148	35.	Depth Crank Complete	CM-1026X
13.	Toggle Switch	CM-1099MA	36.	Dial Plate Complete	CM-1050
14.	Crank Bearing	CM-1045	37.	Lateral Feed Shaft	CM-1047B
15.	Set Screw	9100-11	38.	Lens	CM-1012
16.	Motor Pulley	CM-1060B	39.	Brush	TYX-3
17.	Washer	CM-50149	40.	Brush Nut	9150-29
18.	Motor (110 V)	CM-1080MA	41.	Belt Guard	CM-1014B
19.	Cap Screw	CM-50167	42.	Brush Guard	CM-1096B
20.	Washer	CM-50167-1	43.	Screw	CM-50154
21.	Motor Mounting Bracket	CM-1040MA	44.	AC-Cord	CM-1294MAO
22.	Set Screw	CM-50165	45.	Motor Support	CM-50186
23.	Cotter Pin	CM-62CP	46.	Motor Support Screws (2)	CM-50188

# 1200CMB

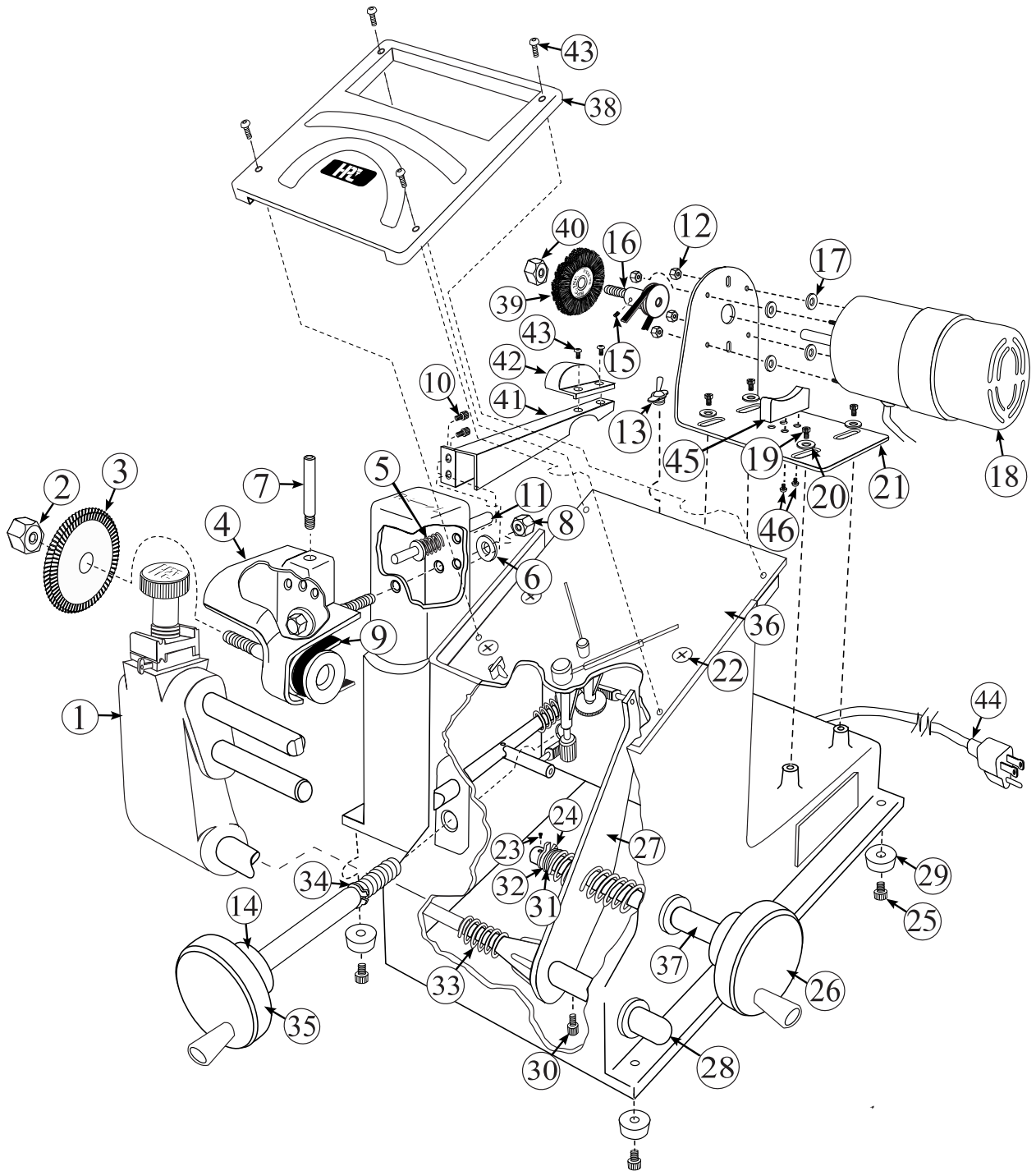

# 1200CMBACDC PARTS LISTING

#	Description	Stock #	#	Description	Stock #
1.	Pivot Arm Complete	CM-1024X	28.	Pivot Arm Shaft	CM-1034
2.	Cutter Nut	CM-1039MA	29.	Rubber Foot	CM-50133
3.	Cutter	Sold Separately	30.	Dogging Screw	CM-1016
4.	Cutter Head Assembly Complete	CM-1053X	31.	Teflon Washer	CM-1086
5.	Spring	CM-1079	32.	Washer	CM-50100
6.	Washer	CM-50100	33.	Spring	CM-1098
7.	Pivot Pin	CM-1043	34.	Retaining Ring	CM-50126
8.	Hex Nut	CM-50157	35.	Depth Crank Complete	CM-1026X
9.	Belt	CM-1083MA	36.	Depth Crank Shaft	CM-1031B
10.	Cap Screw	CM-50158	37.	Transformer for ACDC	ACDC-TRANS
11.	Angle Index Pin	CM-1042	39.	Set Screw	CM-50112
12.	Hex Nut	CM-50148	38.	Dial Plate Complete	CM-1050
13.	Toggle Switch	ACDC-SW	39.	Lateral Feed Shaft	CM-1047B
14.	Crank Bearing	CM-1045	40.	Screw	CM-50154
15.	Set Screw	9100-11	41.	Lens	CM-1012
16.	Motor Pulley	CM-1060B	42.	Brush	TYX-3
17.	Washer	CM-50149	43.	Screw	CM-50134
18.	Motor (12 V DC)	DC-MOTOR	44.	Belt Guard	CM-1014B
19.	Cap Screw	CM-50167	45.	Brush Guard	CM-1096B
20.	Washer	CM-50167-1	46.	Screw	CM-50177
21.	Motor Mounting Bracket	CM-1040MA	47.	Cap Screw	9100-28
22.	Set Screw	CM-50165	48.	Washer	CM-50130
23.	Cotter Pin	CM-62CP	49.	Base	CM-1255MAO
24.	Retaining Ring	CM-50183	50.	Rectifier	ACDC-RECT
25.	Cap Screw	CM-50134	51.	Cap Screw	CM-50167
26.	Lateral Crank Complete	CM-1044X	52.	AC Cord	CM-1294MAO
27.	Lateral Rack Bracket	CM-1030	53.	DC-Cord	DC-CABLE
			54.	Motor Support	CM-50186
			55.	Motor Support Screws (2)	CM-50188

# 1200CMBACDC

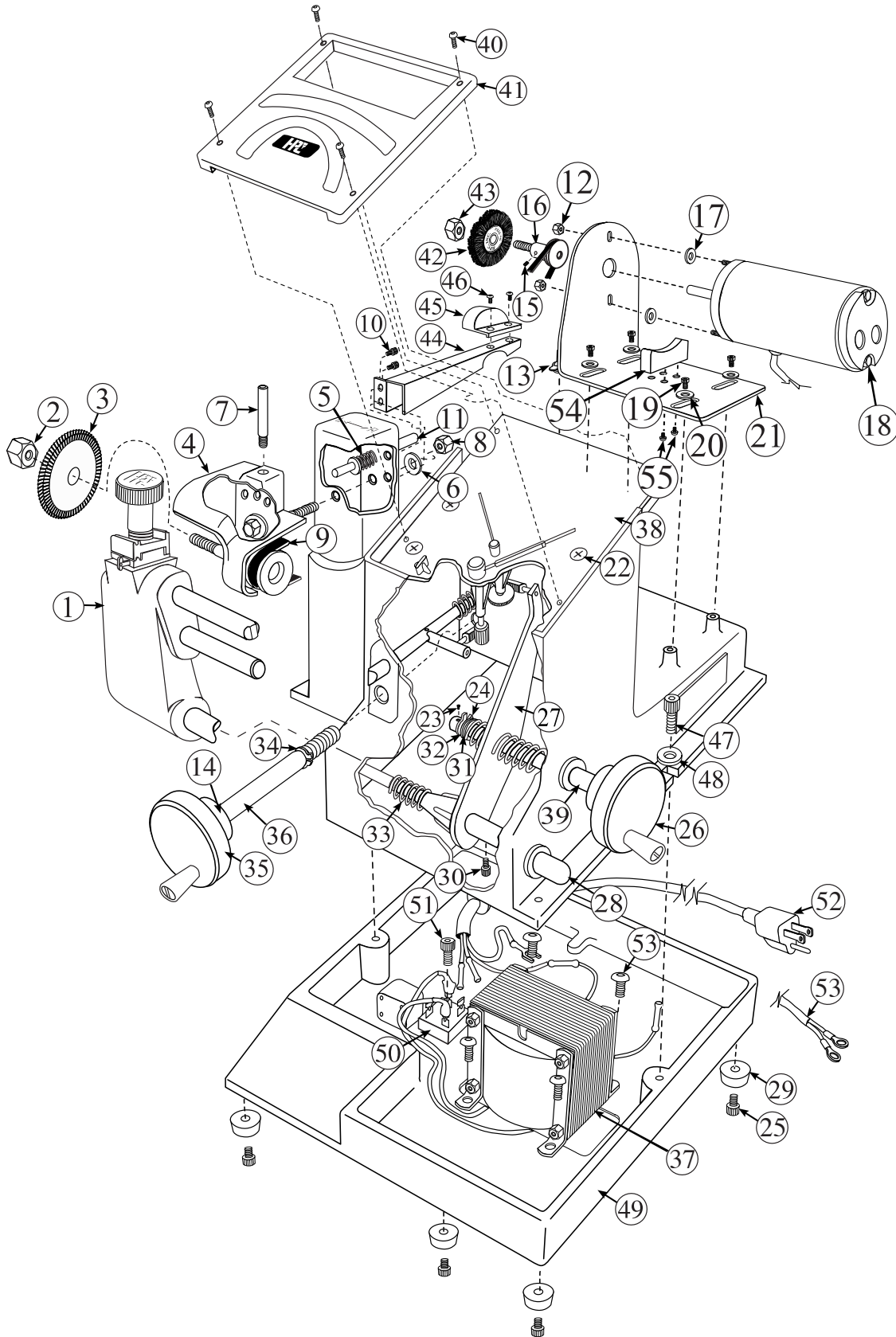

# 1200CM/1200CMB CUTTER HEAD ASSEMBLY

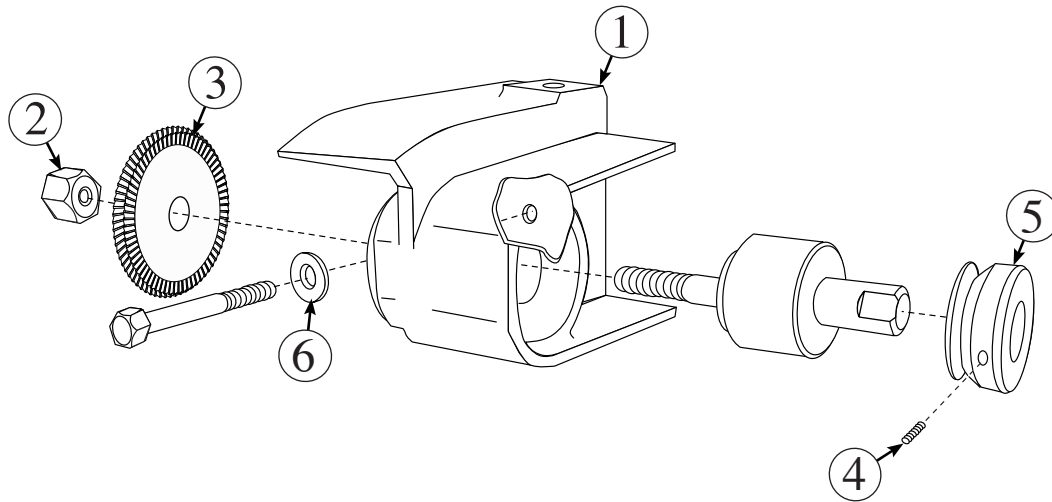

#	Description	Stock #
1.	Cutter Head	CM-1053X (available complete only)
2.	Cutter Nut	CM-1039MA
3.	Cutter	Wide Selection Available
4.	Set Screw	9100-11
5.	Cutter Head Pulley	CM-1059
6.	Washer	CM-50100



# 1200CM/1200CMB PIVOT ARM ASSEMBLY

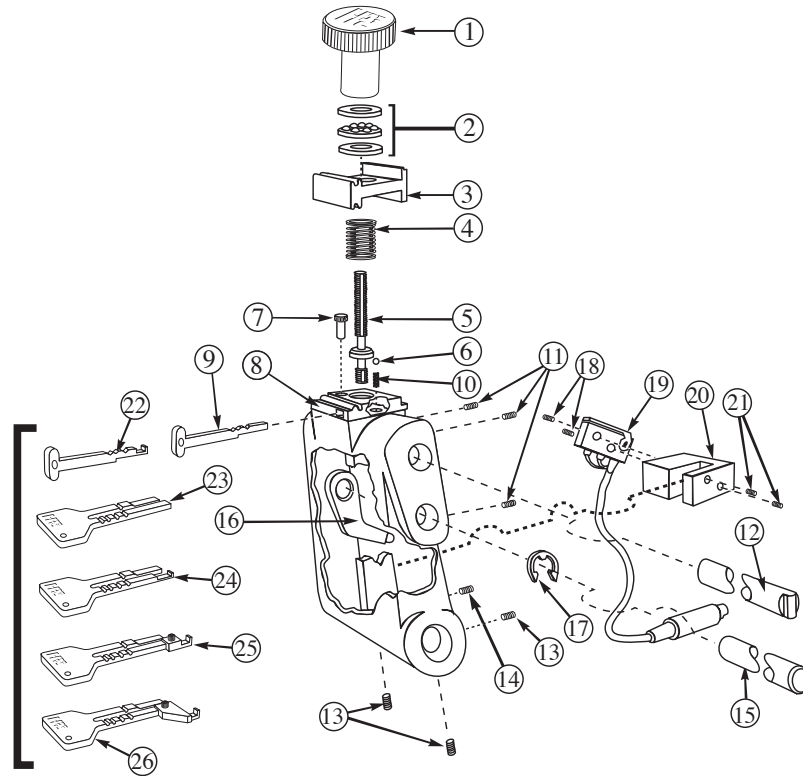

#	Description	Stock #
1.	Easy Grip Wing Nut	EGN-1
2.	Ball Bearing Washer	BBW-2
3.	Top Jaw	CM-1056MA
4.	Spring	CM-1293MA
5.	Stud	CM-1019MA
6.	Ball Bearing	CM-50108
7.	Set Screw	CM-50110
8.	Bottom Jaw (factory installation recommended)	CM-1055MA
9.	Tip Stop	CM-1054MA
10.	Spring	CM-1090MA
11.	Set Screw	CM-50139
12.	Eccentric Shaft	CM-1041
13.	Set Screw	CM-50109
14.	Set Screw	CM-50112
15. & 16	Turn Bar & Shoulder Gauge	CMB-FG
17.	Retaining Ring	CM-50105
18.	2-56 Screw	MAX-92
19.	Shoulder Gauge Wire Assembly	MAX-90
20.	Shoulder Gauge Micro Switch Bracket	MAX-91
21.	6-32 Set Screw	MAX-89
22.	Specialty Tip Stop - Safe Deposit Keys	RT-SD
23.	Horseshoe Tip Stop	CM-1054R
24.	Specialty Tip Stop - Safe Deposit Keys	HT-SD
25.	Specialty Tip Stop - L & F Safe Deposit Box Keys	HT-125
26.	Specialty Tip Stop - L & F Safe Deposit Box Keys	HT-625

# 1200CMB RACK BRACKET ASSEMBLY

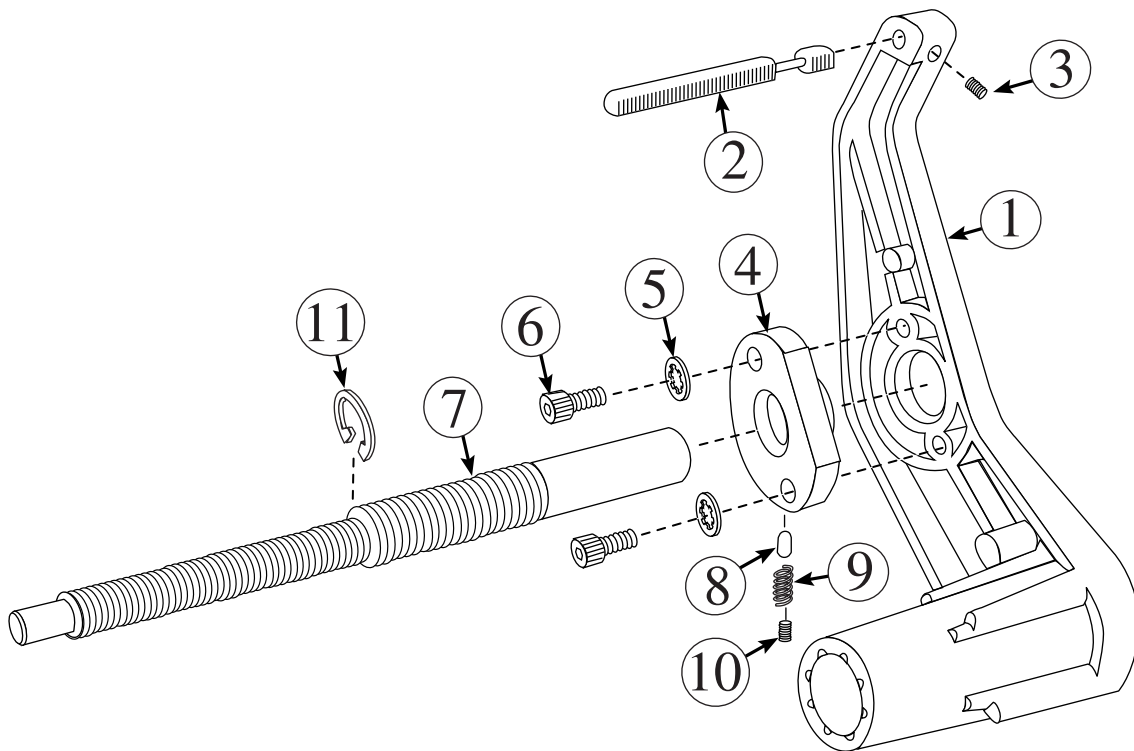

#	Description	Stock #
1.	Rack Bracket	CM-1030B
2.	Lateral Rack	CM-1021
3.	Screw	CM-50112
4.	Feed Thread	CM-1037B
5.	Washer	CM-10150
6.	Screw	CM-50116
7.	Lateral Feed Shaft	CM-1047B
8.	Brake Pellet	CM-50180
9.	Spring	CM-50181
10.	Set Screw	CM-50182
11.	Ring	CM-50183

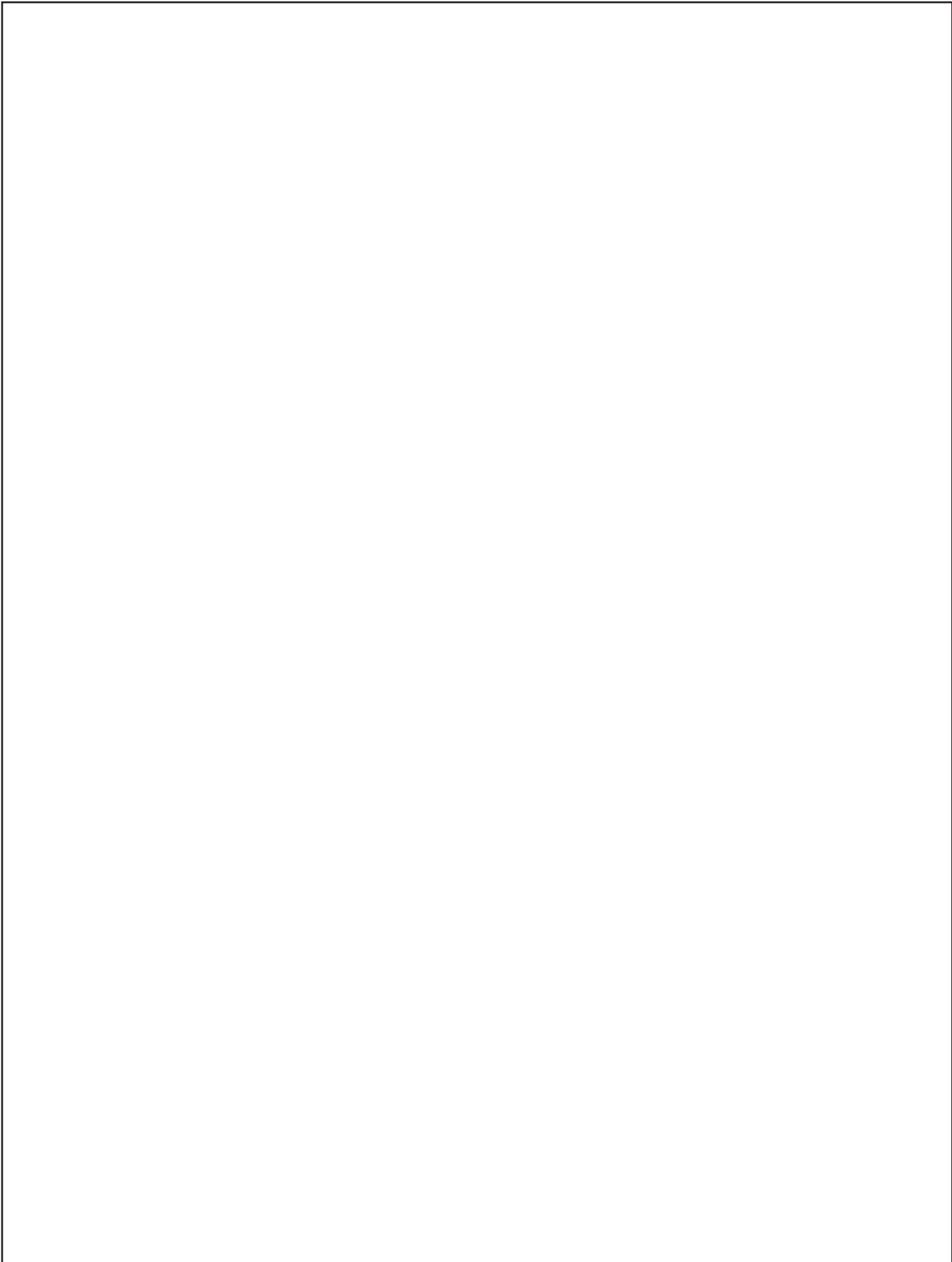

**Blitz™**  
No. 1200CMB



